

ORSCO lubrication systems

- Extend chain life and reduce oil consumption
- Short-term return on investment (ROI)
- Cleaner conditions, less downtime and overall energy savings



ORSCO series 170



The secret of the ORSCO series 170 is its unique ability to provide the right amount of lubricant, at the right location and at the right time, by delivering a small amount of lubricant on a continual and controlled basis. There are no worries about reliability or durability as the ORSCO series 170 has been tested at the maximum injector rate for millions of cycles.



Pulp and paper industry

Spray nozzle advantage: Cleaning effect

Applying lubricant in a continuous fashion provides the best on-going continual maintenance for your chain and keeps all the moving parts as clean as possible, as shown.

The ORSCO concept

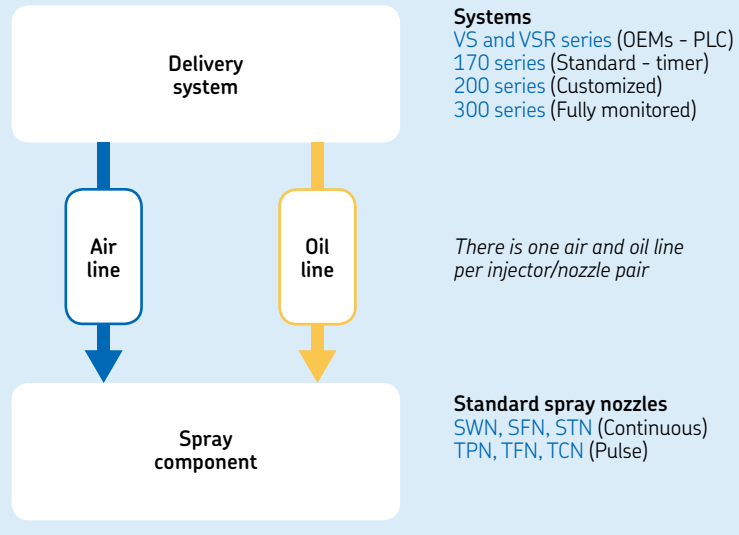

ORSCO system components

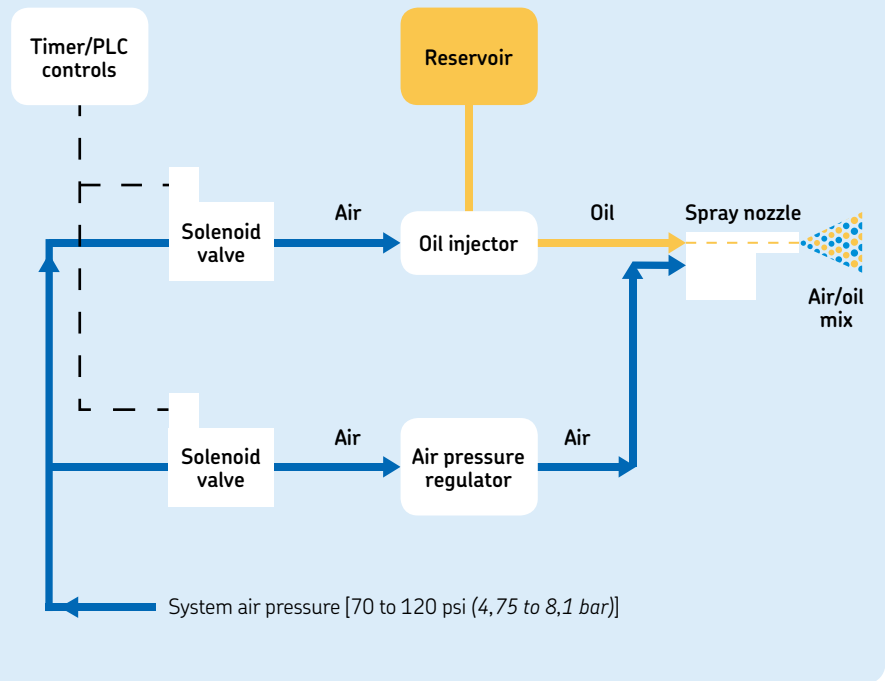

Product features

A complete system

- Original equipment manufacturer (OEM) or installed on site
- Combines controls, valves stack and reservoir

High-output capacity

- Half drop (0.015 cc)
- Two drop (0.060 cc)
- Can deliver up to four drops per second (combined injector output) for large amounts of lubrication
- Available in both non-adjustable and adjustable versions

Compact and easy to maintain

- Manifold design, compact
- Can service part of assembly if necessary
- Easy to set up

Applications

- High-speed conveyors
- Baking and processing ovens
- Overhead conveyors
- Lubricate up to 16 points with one system
- Numerous control options
- Part lubrication
- Material coverage

Features and benefits

- Fixed volume delivery improves lubricant control
- High injector cycle rate (up to 1 Hz) can accommodate applications requiring large amounts of lubricant
- Three-piece reservoir design makes fluid levels easy to see and the component easy to clean and field repair
- Compact modular design with minimal external piping is ideal for OEM applications
- Patented spray nozzle design
- Easily adaptable modular package

Modular packages for OEMs and end-users

Valve stack (VS) series

The valve stack, the heart of the ORSCO family of lubrication products, comes standard with one control network per stack and feeds up to eight injectors. This is a great lubrication solution when matched with a customer's programmable logic controller (PLC) and existing fluid source.

Note: Filter pressure switch is not standard with the VS series product

VS series (non-adjustable)

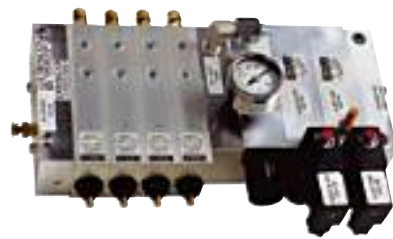

VS series (adjustable)

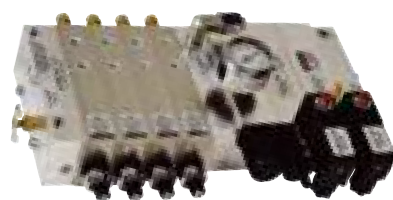

Valve stack-reservoir (VSR) series

By adding a reservoir and a filter pressure switch, this package comes ready to work with a customer's timer or programmable logic controller (PLC).

VSR series



Ideal for many industries



Pulp and paper industry



Beverage industry



Textile industry (tenter frame applications)



Waste water treatment

Series 170 system

A standard and easy-to-install system for up to 16 lubrication points with multiple variations to choose.

ORSCO series 200 and 300

Series 200 is available for custom solutions requiring over 16 points of lubrication.

Series 300 is for real-time pressure monitoring of lubrication system.



Products



Food processing/baking industry



Automotive industry



Material handling industry

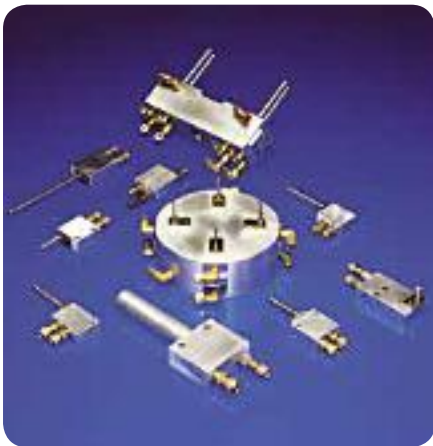

Customized oil spray nozzles

If necessary, ORSCO will custom design nozzles or systems specific to the particular application.

At ORSCO . . .

- We don't make lubricants, we make lubricants work better!
- We don't make chains, we make chains last longer!
- We don't make machines, we make machines more productive!



Industrial applications

Industry	Series 170	Series 200	Series 300
Assembly	•	•	•
Automotive	•	•	•
Baking	•	•	
Beverage	•	•	
Fiberglass	•	•	
Food processing	•	•	
Gypsum	•	•	
Industrial ovens	•	•	
Machine tool	•	•	•
Material handling	•	•	
Plastic	•	•	• ¹⁾
Pulp and paper	•	•	
Textile	•	•	• ¹⁾
Waste water	•	•	

¹⁾ Tenter frame applications

Patented precision delivery nozzles

Choose from three tip lengths and three spray patterns for versatility in any continuous or pulsed spray design application. These nozzles feature 1/4-20 tapped (#10 screw clearance) mounting holes and durable aluminum construction.

Continuous-spray nozzles



SWN IL type



SWN LP type

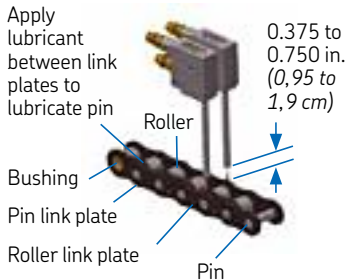

Order number configurator

SWN	-	IL	-	NC	-	90	-	2
TPN	-	LP	-	NC	-	00	-	3

Standard nozzles
SWN = Continuous spray
TPN = Pulse spray

Body style
IL = In line
SS-IL = Stainless steel in line
LP = Low profile
SS-LP = Stainless steel low profile

Fittings
NC = Nylon compression fitting - standard
NY = Nylon push in tube fitting
CS = Carbon steel fitting (steel tubing)
SS = Stainless steel fitting (steel tubing)
XX = No fittings

Oil lines
 Nylon - 3/16 in. tubing
 Steel tube - 1/8 in. OD tubing

Air lines
 Nylon - 1/4 in. tubing
 Steel tube - 1/4 in. OD tubing

Spray pattern angle
00 = 0° (straight)
45 = 45°
90 = 90°

Tip length
1 = 1 in.
2 = 2 in.
3 = 3 in.

For custom nozzle design, contact your ORSCO representative.

Other popular nozzle families



TPN standard
 Pulse-Spray Nozzle
 Assembly applications and slow moving chains



TFN
 Pulse-Spray 360° Fan Nozzle
 Bore lube and general assembly applications



TCN
 Pulse-Spray Cone Nozzle
 Engine and general assembly applications



SWN standard
 Continuous-Spray Nozzle
 Chain/gears/exposed bearings/assembly applications



SFN
 Continuous-Spray 120° Fan Nozzle
 Metal stamping/metal forming/food applications



HFN
 Continuous-Spray High-Flow Nozzle
 Spindle applications

Packaged systems

170 series

A standard and easy-to-install system for up to 16 lubrication points. Systems include an internal timer to control injector cycle rate.

Note: Dual network indicates that half of the lubrication points are controlled by their own timer. Package includes appropriate number of spray nozzles of the type SWN-LP-NC-00-3, stainless steel nozzle mounting bracket and 25 ft. (7,6 m) nylon lines per lubrication point.

Series 170 lubrication systems

Model	Injector size ¹⁾	No. of networks	No. of injectors	Voltage ²⁾ (USD)
170-512AO	0.015	1	2	120 V AC
170-514AO	0.015	1	4	120 V AC
170-524AO	0.015	2	4	120 V AC
170-528AO	0.015	2	8	120 V AC

¹⁾ For double-drop injectors replace "5" with a "2" (i.e., 170-214AO)

²⁾ For 24 V DC voltage replace "A" with "D" (i.e., 170-524D0)

VSR series

ORSCO valve stack with reservoir and filter regulator/pressure switch. The system comes ready to work with a customer's timer or PLC. Package includes appropriate number of spray nozzles of the type SWN-LP-NC-00-3, stainless steel nozzle mounting bracket and 25 ft. (7,6 m) nylon lines per lubrication point.

Note: Packaged systems are for continuous spray applications only.

Series VSR lubrication systems

Model	Injector size ¹⁾	No. of networks	No. of injectors	Voltage ²⁾
VSR-512AO	0.015	1	2	120 V AC
VSR-514AO	0.015	1	4	120 V AC
VSR-524AO	0.015	2	4	120 V AC
VSR-528AO	0.015	2	8	120 V AC

¹⁾ For double-drop injectors replace "5" with a "2" (i.e., VSR-214AO)

²⁾ For 24 V DC voltage replace "A" with "D" (i.e., VSR-524D0)

Please contact ORSCO to quote your specific application.



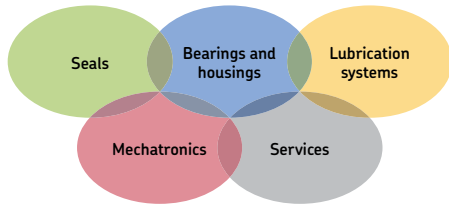

The Power of Knowledge Engineering

Combining products, people, and application-specific knowledge, SKF delivers innovative solutions to equipment manufacturers and production facilities in every major industry world-wide. Having expertise in multiple competence areas supports SKF Life Cycle Management, a proven approach to improving equipment reliability, optimizing operational and energy efficiency and reducing total cost of ownership.

These competence areas include bearings and units, seals, lubrication systems, mechatronics, and a wide range of services, from 3-D computer modelling to cloud-based condition monitoring and asset management services.

SKF's global footprint provides SKF customers with uniform quality standards and worldwide product availability. Our local presence provides direct access to the experience, knowledge and ingenuity of SKF people.

Other automated lubrication systems (ALS)



EOS system

A low-cost, economical system for precise metered quantities of oil to reduce chain and sprocket wear.



VSP system

A pneumatic-only controlled VSR made especially for applications prohibiting the use of electrical systems.



Custom controls

Custom controls designed to meet special application requirements.



Accessories

Spring-loaded bracket and other accessories such as fiberglass enclosures and stainless steel fittings available only from ORSCO.

Please contact:

ORSCO, Inc.

14165 Rick Drive

Shelby Township, MI 48315 USA

Tel. +1 (586) 997-0300

© SKF is a registered trademark of the SKF Group.

© Lincoln and ORSCO are registered trademarks of Lincoln Industrial Corp.

© SKF Group 2014

The contents of this publication are the copyright of the publisher and may not be reproduced (even extracts) unless prior written permission is granted. Every care has been taken to ensure the accuracy of the information contained in this publication but no liability can be accepted for any loss or damage whether direct, indirect or consequential arising out of the use of the information contained herein.

PUB LS/P2 14654 EN · May 2014 · Form 442919

