

SKF VectoLub, VE1B units

External minimal quantity lubrication,
Volumetric metering



The eMQL system SKF VectoLub is a clean and economical alternative for lubricant projection in minimal quantity.

The SKF VectoLub system works with volumetric micropumps, which deliver very small quantities of lubricant (starting at 3 mm³) at a high frequency to the friction point by the use of a bifluid projection nozzle. This system is used for:

- Machining, drawing, sawing,
- Lubricant coating,
- Conveyors lubrication.



The VE1B units are compact, easy to use and economical lubrication systems. You can mount the VE1B unit directly on the machine frame by the use of standard fixing rails or a magnetic foot.

Advantages

- Higher machining performance (higher speeds when cutting and parting).
- Better surface finish thanks to lower (friction-induced) temperature.
- Long tool life, mainly when high-frequency machining is involved.
- Exact adjustment of delivery rate saves lubricant.
- The lubricant is consumed during the machining process. No residue is left on the workpiece or chips. No disposal of lubricant residue, no degreasing of parts and chips.
- Greater safety and environmental hygiene at the workplace. No mist, clean air to breathe.
- Fast amortization of the system.
- Compact unit, to be installed as close as possible to the application.

VE1B unit, function

The VE1B unit is fed in lubricant from an integrated reservoir, capacity 0,3 l, or from the user's external reservoir. Compressed air is also supplied to the unit from the user's network. In general the air inlet is controlled with a solenoid valve (here as option).

The compressed air flows through the ground plate of the unit and is distributed on the one hand to each micropump, and on the other hand to the coaxial outlets to be used as carrier air.

Every pneumatically actuated micropump (max. pump frequency 3 pulses/s) delivers the lubricant (starting at 3 mm³/pulse; flow rate adjustable with thumb wheel or metering rings) through the inner capillary tube of the coaxial line into a bifluid projection nozzle.

The working frequency of all micropumps can be adjusted with a pneumatic pulse generator or an electric pulse generator (solenoid valve), which is directly mounted on the unit.

Every outlet has a regulating valve to adjust the pressure of the carrier air.

Coaxial lines are connected to the outlets with quick connectors.

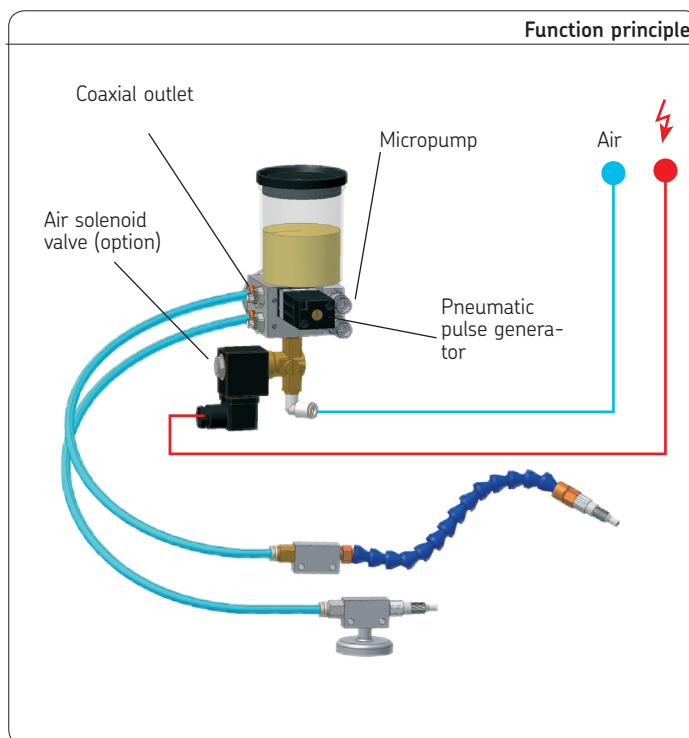

The SKF VectoLub technology

The SKF VectoLub technology has proved itself for many years. It is based on the combination of very small quantities of lubricant (3 to 90 mm³), fed by a pneumatically actuated volumetric micropump, and a flow of compressed air called "carrier air".

Lubricant and carrier air are parallel conducted in an coaxial line to a bifluid spraying nozzle. The air is swirled in the nozzle and breaks down the lubricant into microdroplets (200 to 600 μm) at the nozzle outlet. The lubricant microdroplets are transported by the carrier air to the friction point to generate a fine and homogeneous lubricant film without oil mist formation.

This technology optimizes the lubrication efficiency, reduces the consumption of lubricant and preserves the safety and cleanliness of the working area.

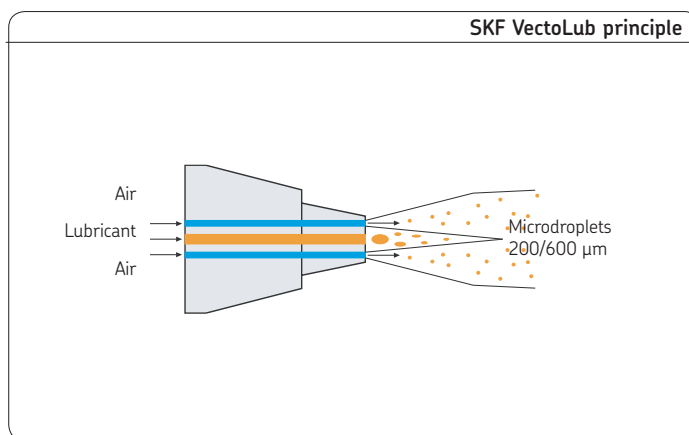

Notice!

See important product usage information on the back cover.
See operating instruction 951-130-441.

Working frequency

The user can adjust the working frequency of the VE1B unit and thus the total flow rate to the needs of the application. Therefore he sets the working frequency of the micropumps. Several methods are available.

Pneumatic pulse generator

The user sets the working frequency of the micropumps with a pneumatic pulse generator. The working frequency ranges from 3 pulses/second to 1 pulse/24 seconds.

Electric pulse generator

A solenoid valve controls the air inlet for the micropump and thus control the working frequency too. An external control unit drives the solenoid valve. The maximal working frequency is 3 pulses/second.

No pulse generator

Some VE1B units are available without a pulse generator. SKF Vogel recommends to fit a solenoid valve upward the VE1B unit. This solenoid valve controls the air inlet (carrier air and control air) of the VE1B unit. See *Accessories*.

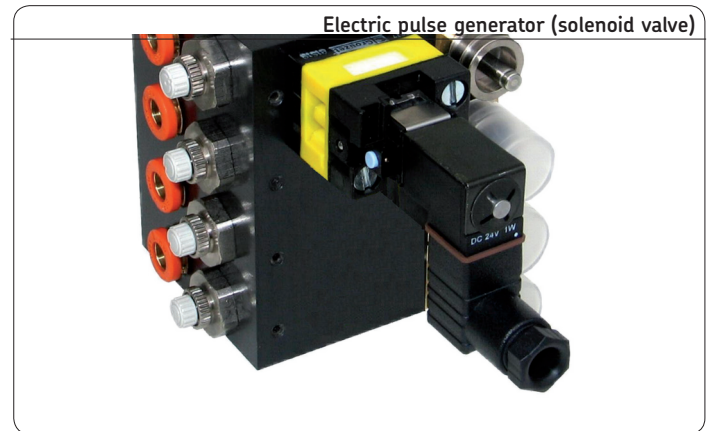
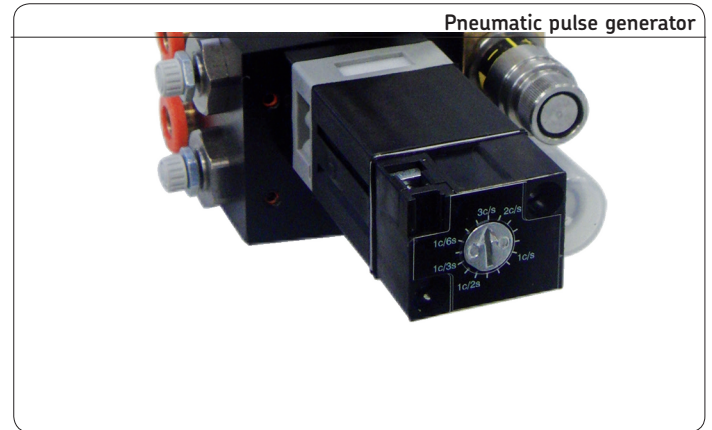

Lubricant flow rate

Flow rate per micropump

Two ranges of flow rate are available:

- small flow
 - 3 to 30 mm³/stroke (setting with metering ring),
 - 10 to 30 mm³/stroke (setting with thumb wheel),
- large flow
 - 30 to 90 mm³/stroke (setting with metering ring or thumb wheel)

The flow rate is given in mm³ for one piston stroke, and the final lubricant outflow, which is necessary for the application, depends on the micropump working frequency.

Setting mode

- Thumb wheel: for the small flow, a thumb wheel turn corresponds to a change of the outflow of 5 mm³/ stroke ; for the large flow 15 mm³/ stroke. It is possible to jam the outflow and a minimal flow is guaranteed with at least 2 complete wheel turns.
- Metering rings: for the small flow there are 6 metering rings (0/3/5/10/15/20) and for the large flow 4 metering rings (0/30/45/60). To get the maximal flow rate for every micropump, which is 30 mm³ for small flow and 90 mm³ for large flow, the user puts no metering ring.

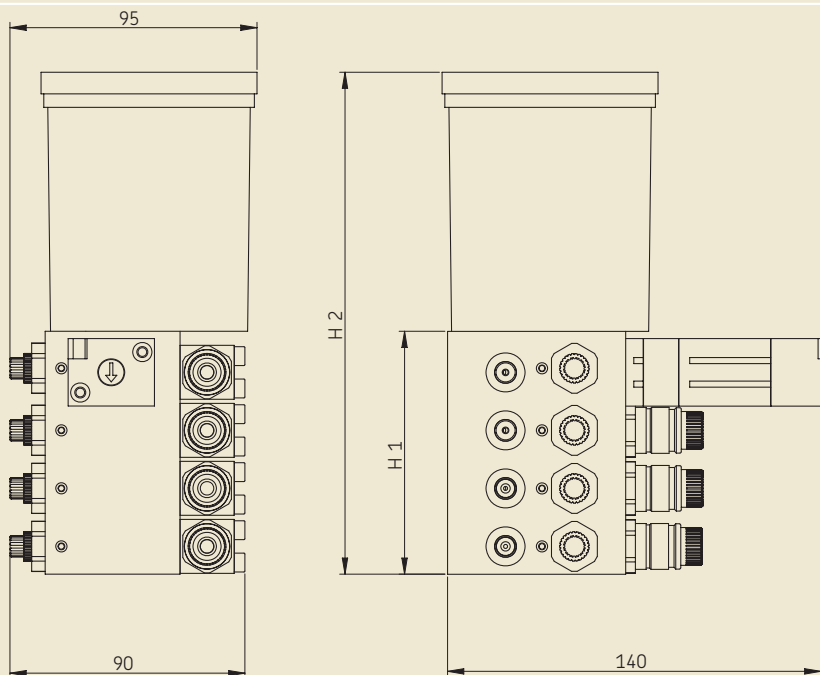

VE1B unit dimensions

micropumps	H1	H2
1	26	122
2	45	141
3	90	186
4	90	186

Technical data

General

- Number of outlets 1 to 4
- Min. air inlet 400 NI/min
dry and filtered air (5 µm)
- Air inlet pressure 5 to 8 bar
- Air inlet connection G 1/4 cylindrical
- Lubricant inlet connection G 1/4 cylindrical

- Micropump delivery rate
 - metering rings (small) 3 to 30 mm³/stroke
 - metering rings (large) 30 to 90 mm³/stroke
 - thumb wheel (small) 10 to 30 mm³/stroke
 - thumb wheel (large) 30 to 90 mm³/stroke
- Max. pump working frequency 3 strokes/s

Lubricant mineral or synthetic oil,
or biodegradable oil

- Effective viscosity 10 to 400 mm²/s
(operating temperature)
- Service temperature 10 to 50 °C
- Weight 1,5 kg
(with integrated reservoir and all options)

Solenoid valve (electric pulse generator)

- Delivery rate (at 6 bar) 150 NI/min
- Power supply
 - + 428 230 V AC – 50/60 Hz – 2,5 W
 - + 429 115 V AC – 50/60 Hz – 2,5 W
 - + 924 24 V DC – 1 W
- Protection IP 65
- Interface logic element
- Mechanical life 1,5 × 10⁷ switching operations

Pneumatic pulse generator

- Delivery rate (at 6 bar) 170 NI/min
- Mechanical life > 1 × 10⁷ switching operations
- Frequency 0,166 to 3 Hz

Integrated reservoir

- Capacity 0,3 liter
- Lubricant level monitoring
- Visual monitoring transparent reservoir

Recommended lubricant

The VE1B unit can deliver mineral or synthetic oil, ecological oil, with an effective viscosity between 10 and 400 mm²/s at operating temperature. Vanishing lubricants have to contain 5 to 10% of greasy substance.

VE1B unit

Order No.

VE1B - - - + - -

Control type

- O = without
- P = pneumatic pulse generator
- E = electric pulse generator (solenoid valve)

Pumps

- A = setting with metering rings, 3 to 30 mm³/stroke, brass
- B = setting with thumb wheel, 10 to 30 mm³/stroke, brass
- C = setting with metering rings, 3 to 30 mm³/stroke, stainless steel
- D = setting with thumb wheel, 10 to 30 mm³/stroke, stainless steel
- E = setting with metering rings, 30 to 90 mm³/stroke, brass
- F = setting with thumb wheel, 30 to 90 mm³/stroke, brass
- G = setting with metering rings, 30 to 90 mm³/stroke, stainless steel
- H = setting with thumb wheel, 30 to 90 mm³/stroke, stainless steel

Number of micropumps

- 1, 2, 3 or 4

Reservoir

- 00 = without
- 10 = with integrated reservoir 0,3 l

Voltage key*

- 428 for 230 V AC, 50/60 Hz,
- 429 for 115 V AC, 50/60 Hz,
- 924 for 24 V DC

Order example

VE1B unit with 4 outlets, controlled by a pneumatic pulse generator, with a reservoir, small flow micropump, brass, adjustment with thumb wheel, Order No. **VE1B-PB4-10b**

*) When the solenoid valve is selected, the voltage key has to be added to the order number

Accessories

General air solenoid valve

The solenoid valve is fitted upstream the VE1B unit and controls the air inlet (carrier air and control air).

Order No. **MOD-1016+ ___**



Technical data

Delivery rate (at 7 bar)	430 NI/min
Power supply*	
+ 428.	230 V AC – 50/60 Hz – 2,5 W inrush power 26 VA holding power 14 VA
+ 429.	115 V AC – 50/60 Hz – 2,5 W inrush power 26 VA holding power 14 VA
+ 924.	24 V DC – 14 W
Protection	IP 65
Mechanical life	1,5 × 10 ⁶ switching operations
Sizes	82,5 × 94 × 30 mm
Weight	ca. 0,2 kg

**) The order number has to be completed with the voltage key*

Fastening the VE1B unit

Rail and clips for a permanent fixation, weight ca. 0,3 kg

Order No. **MOD-1011**

Magnetic foot for a movable fixation, weight ca. 0,3 kg

Order No. **AC-3228-M**

Quick-release connector on a G 1/4 port for a tube Ø 8

Lubricant inlet (no integrated reservoir)

Order No. **RC.802**

Air inlet

Order No. **RC.803.N**

Nozzles and tubing see leaflet 1-4402-EN

Reservoirs see leaflet 1-4402-EN

Order No.: 1-4403-EN

Subject to change without notice! (10/2015)

Important product usage information

All products from SKF may be used only for their intended purpose as described in this brochure and in any instructions. If operating instructions are supplied with the products, they must be read and followed.

Not all lubricants are suitable for use in centralized lubrication systems.

SKF does offer an inspection service to test customer supplied lubricant to determine if it can be used in a centralized system. SKF lubrication systems or their components are not approved for use with gases, liquefied gases, pressurized gases in solution and fluids with a vapor pressure exceeding normal atmospheric pressure (1013 mbars) by more than 0,5 bar at their maximum permissible temperature.

Hazardous materials of any kind, especially the materials classified as hazardous by European Community Directive EC 67/548/EEC, Article 2, Par. 2, may only be used to fill SKF centralized lubrication systems and components and delivered and/or distributed with the same after consulting with and receiving written approval from SKF.

Further brochures

1-9201-EN Transport of Lubricants in Centralized Lubrication Systems

This brochure was presented by:

® SKF and VectoLub are registered trademarks of the SKF Group.

© SKF Group 2015

The contents of this publication are the copyright of the publisher and may not be reproduced (even extracts) unless prior written permission is granted. Every care has been taken to ensure the accuracy of the information contained in this publication but no liability can be accepted for any loss or damage whether direct, indirect or consequential arising out of the use of the information contained herein.

