

DH.N metering unit

SKF DosaLub

Metering unit for oil or grease up to NLGI grade 2, from 0,05 to 3 cm³ per stroke

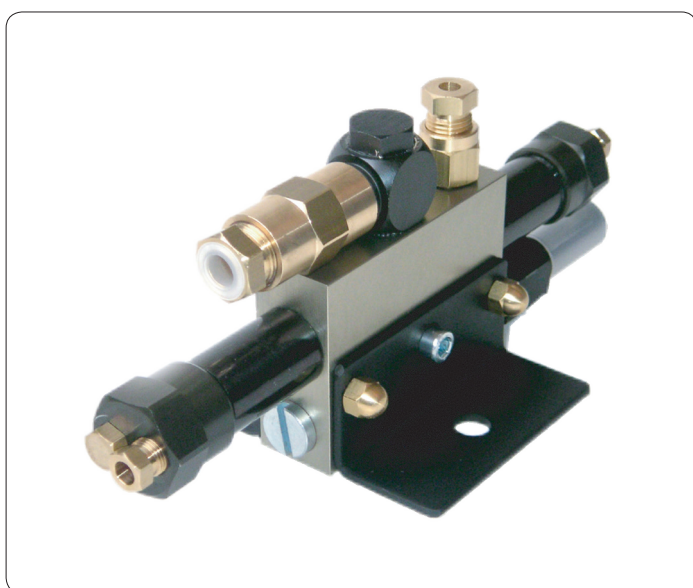

The metering unit DH.N has been designed to meet the requirements of the industrial mounting and assembly lines for lubricant deposit, injection and filling.

It can feed metered volume of lubricant, from 0,05 cm³ to 3 cm³ per metering cycle to the lubrication point in order to improve the mechanical properties of diverse parts like:

- Car parts (control arms, seat tracks),
- Motors, transmissions, brake gears,
- Electric household appliances (small gear motors),
- Ball bearings,
- Locking systems, tec.

Advantages

- Very precise metered quantities
- Volumetric metering independent of any change in temperature or lubricant viscosity
- Very good repeatability over the time
- Easily adjustable (outer set screw)
- Possibility to electrically monitor the metering cycle with inductive proximity switch(es)
- Long service life thanks to the component sturdiness
- One or several outlets on the same unit (juxtaposition of several units)

Design

The DH.N metering units are made of one or several piston modules, which are placed side by side and pneumatically actuated.

There are two pistons in each module:

- a metering piston, which is determining the metered volume of lubricant, independently of any change in temperature or lubricant viscosity. The good function of the piston can be checked outside thanks to an indicating rod.
- a control piston, which is pneumatically actuated by two single-acting cylinder.

Proximity switches can control the metering piston stroke.

- **1 Sensor:** version 1.04, control of the back stroke
- **2 Sensors:** Version 2.04, control of the double stroke

Lubricant is supplied under pressure to the metering unit.

When the lower pneumatic cylinder is actuated, the metering unit is delivering a metered volume of lubricant ; when the upper pneumatic cylinder is actuated, then the metering unit is fed up with lubricant.

DH.N

- 1 Proximity switch (filling phase)
- 2 Metering set screw
- 3 Indicating rod
- 4 Mounting bracket
- 5 Proximity switch (delivery phase)
- 6 Air inlets
- 7 Bridging holes (to group several outlets)
- 8 Lubricant inlet
- 9 Lubricant outlet

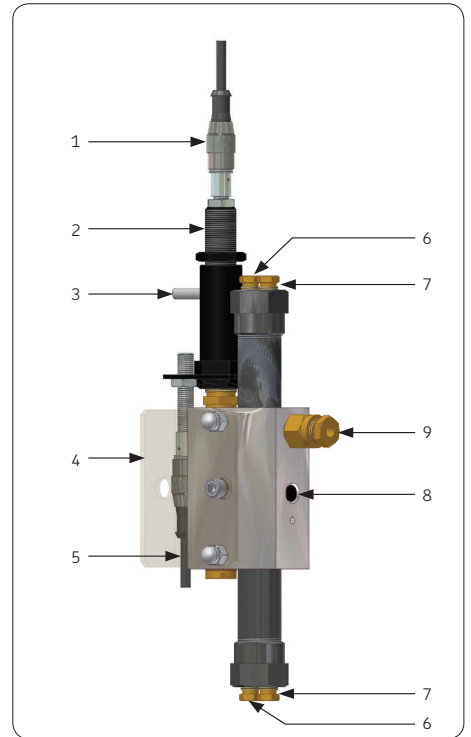

Function principle

A metering cycle consists of two distinct phases: filling (back stroke) and delivery (outward stroke). These two phases are pneumatically actuated. Normally a 4/2 way solenoid valve, with manual or electric control, is supplying the metering unit in air.

Filling phase

The upper pneumatic cylinder (1) is set under pressure and is displacing the control piston (2) until its 'lower' end position. At the same time the 'lower' pneumatic cylinder is at atmospheric pressure (3).

Lubricant supplied by e.g. a pump is flowing through channels 4 and 5 of the DH.N unit. As the lower cross-sectional area of the metering piston (6) is larger than the upper one, the thrust is carried out from the lower chamber of the piston. Therefore the metering piston (6) is moving to its upper end position. The stroke of this piston can be adjusted with a set screw (see page 3). The volume of lubricant, which is then underneath the metering piston corresponds to the selected metered quantity.

Delivery phase

The lower pneumatic cylinder (3) is set under pressure and is displacing the control piston (2) until its 'upper' end position. At the same time the 'upper' pneumatic cylinder is at atmospheric pressure (1).

The lubricant is now flowing via channel 4 to the upper chamber of the metering piston (6). The lower channel (5) is now directly connected to the outlet (S) due to the position of the control piston (2). Due to the lubricant pressure the metering piston (6) is moving to its lower end position and is simultaneously ejecting the metered quantity of lubricant to the outlet (S).

Function

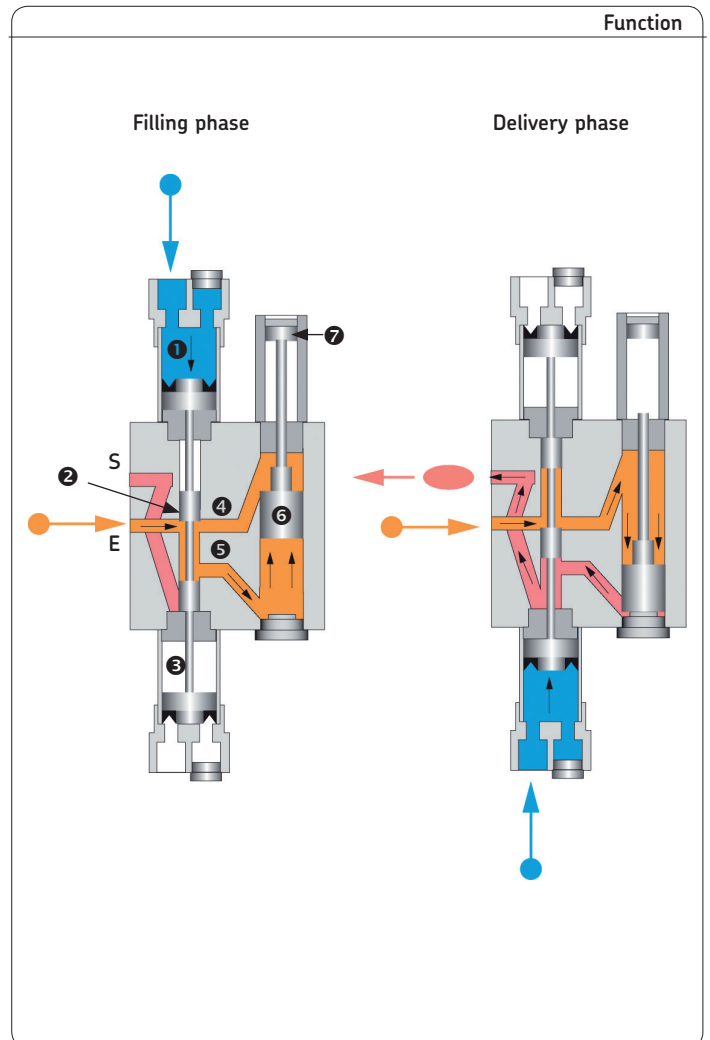

Technical data

General

Number of outlet	1 to 6
Air inlet pressure	4 to 8 bars
Lubricant inlet pressure	70 to 150 bars
Max. Working frequency	1 cycle/3 seconds
Service temperature	15 to 40 °C
Flow rate per outlet	
for unit type SE6	0,05 to 1,3 cm ³
for unit type SE12	0,1 to 3 cm ³
Lubricants	
Oil	20 to 2 000 mm ² /s (at service temperature)
Grease	up to NLGI grade 2 (homogeneous and free of air)

Material

piston	steel
body	treated aluminium
Position monitoring	1 or 2 proximity switches

Proximity switch(es)

Type	inductive proximity switch
Function	NC
Sensing distance	1,5 mm
Operating voltage	24 to 240 V (50/60Hz)
Load current	5 to 100 mA
Protection	IP 67
Output status signal	LED 4 positions at 90°
Cylindrical threaded shape M8×1	
Material	stainless steel
Connection	straight male connector, cylindrical 1/2" – 20 UNF – 1B, sealed-in 2 m cable

Wiring diagram of the proximity switch

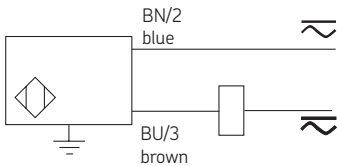

See important product usage information on the back cover.

How to adjust the metering unit?

Metering unit DH.N with sight monitoring (without proximity switch)

- Remove the plastic protection cap
- Loosen and remove the tightening screw (1)
- Screw in the metering screw (2) unit until its lower end position
- You can now adjust the flow rate. Screw off the metering screw (2):
 - DH.N._SE6 1 turn = 0,0625 cm³ (± 5 %)
 - DH.N._SE12 1 turn = 0,140 cm³ (± 5 %)
- When the selected metered volume is reached, put back the tightening screw (1) and screw it in to its end position against the metering screw (2). Put back the plastic protection cap.

Metered volume adjustment for DH.N without proximity switch

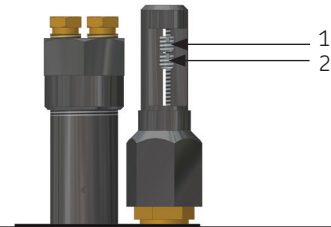

Metering unit DH.N with proximity switch(es)

- Switch off the DH.N metering unit and disconnect the proximity switch (1)
- Screw off the locknut (2)
- Screw in the metering screw (3) unit until its lower end position
- You can now adjust the flow rate. Screw off the metering screw (3):
 - DH.N._SE6 1 turn = 0,05 cm³ (±5 %)
 - DH.N._SE12 1 turn = 0,113 cm³ (±5 %)
- When the selected metered volume is reached, tighten the locknut (2)
- Reconnect the proximity switch (1) and switch on the DH.N unit.

Metered volume adjustment for DH.N with proximity switch(es)

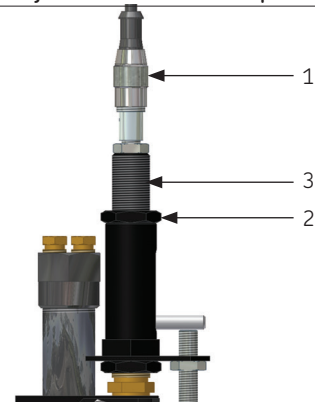

Caution!

The DH.N unit has to be depressurized before adjusting the metered volume.

DH.N metering unit

Order No.	Number of metering units	Flow rate (cm ³ /cycle)		Monitoring	
		0,05 to 1,3	0,1 to 3	1 Sensor	2 Sensors
DH.N.1.SE6	1	•			
DH.N.1.SE6.1.04	1	•		•	
DH.N.1.SE6.2.04	1	•			•
DH.N.1.SE12	1		•		
DH.N.1.SE12.1.04	1		•	•	
DH.N.1.SE12.2.04	1		•		•
DH.N.2.SE6	2	•			
DH.N.2.SE6.1.04	2	•		•	
DH.N.2.SE6.2.04	2	•			•
DH.N.2.SE12	2		•		
DH.N.2.SE12.1.04	2		•	•	
DH.N.2.SE12.2.04	2		•		•
DH.N.3.SE6	3	•			
DH.N.3.SE6.1.04	3	•		•	
DH.N.3.SE6.2.04	3	•			•
DH.N.3.SE12	3		•		
DH.N.3.SE12.1.04	3		•	•	
DH.N.3.SE12.2.04	3		•		•
DH.N.4.SE6	4	•			
DH.N.4.SE6.1.04	4	•		•	
DH.N.4.SE6.2.04	4	•			•
DH.N.4.SE12	4		•		
DH.N.4.SE12.1.04	4		•	•	
DH.N.4.SE12.2.04	4		•		•
DH.N.5.SE6	5	•			
DH.N.5.SE6.1.04	5	•		•	
DH.N.5.SE6.2.04	5	•			•
DH.N.5.SE12	5		•		
DH.N.5.SE12.1.04	5		•	•	
DH.N.5.SE12.2.04	5		•		•
DH.N.6.SE6	6	•			
DH.N.6.SE6.1.04	6	•		•	
DH.N.6.SE6.2.04	6	•			•
DH.N.6.SE12	6		•		
DH.N.6.SE12.1.04	6		•	•	
DH.N.6.SE12.2.04	6		•		•

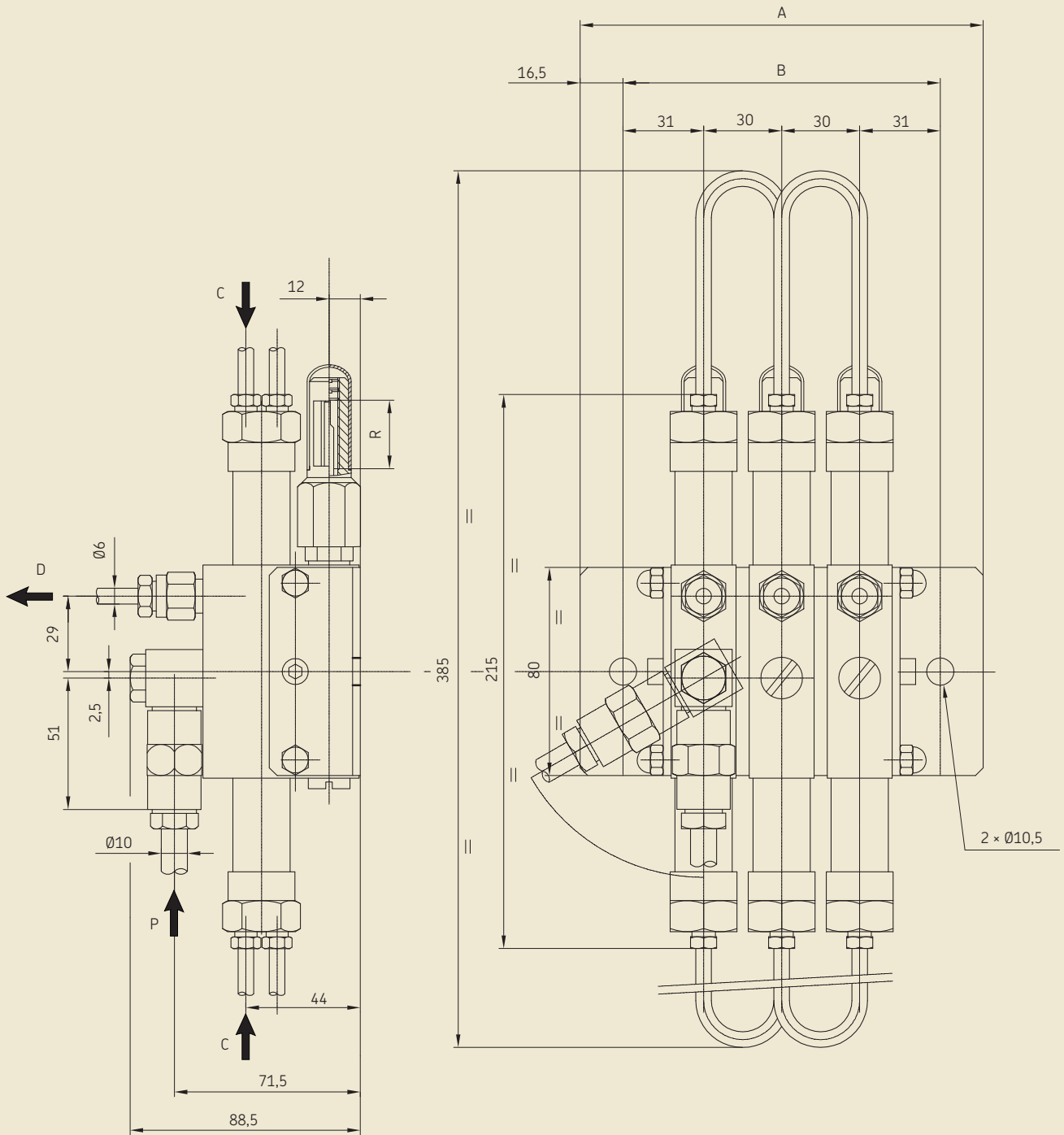

- C Air inlet (tube OD 6)
- D Lubricant outlet (tube OD 6)
- P Lubricant inlet (tube OD 10)
- R Metered volume adjustment (max. stroke: 26 mm)

	Number of elements (outlets)					
	1	2	3	4	5	6
A	95	125	155	185	215	245
B	62	92	122	152	182	212

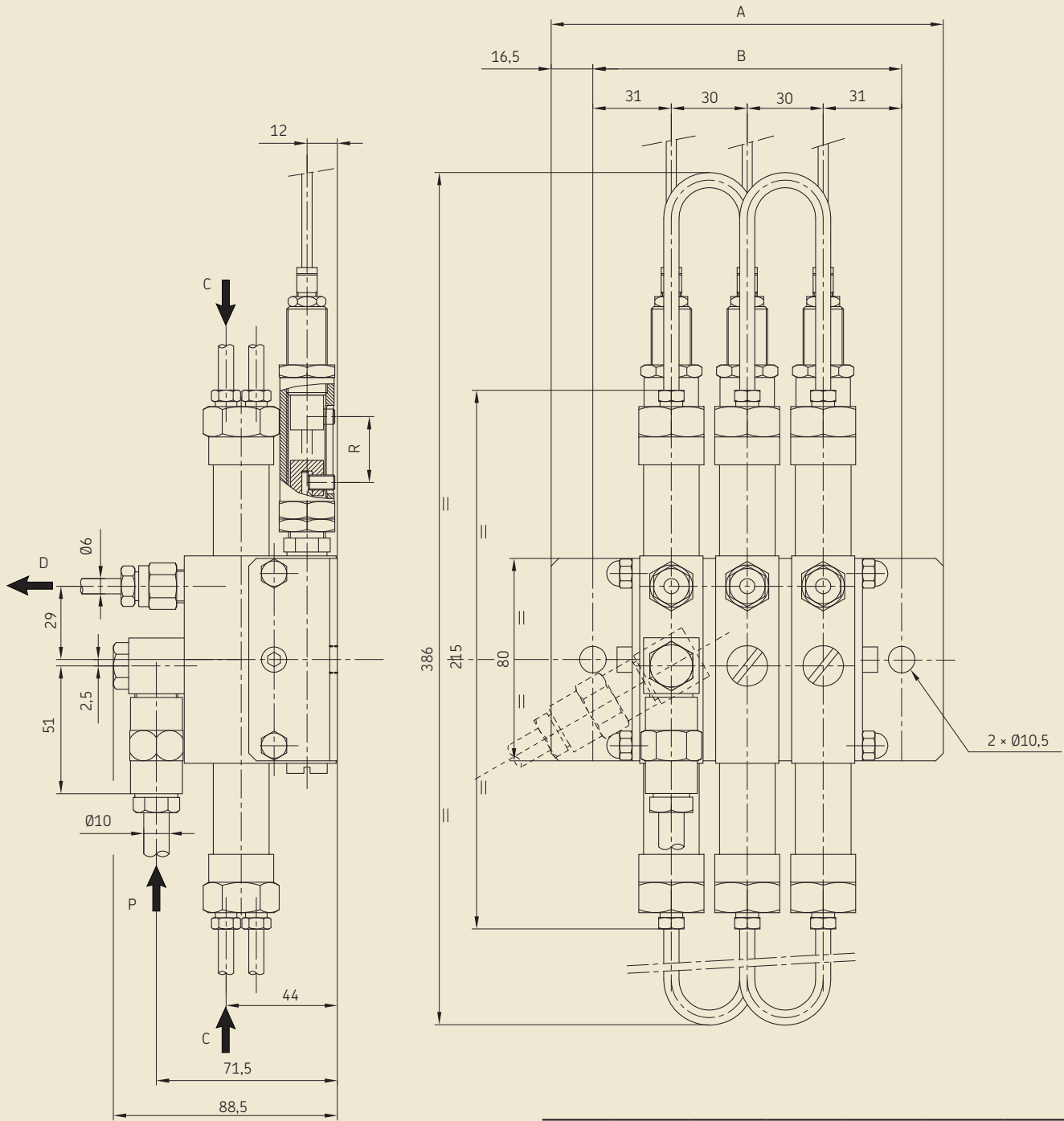

- C Air inlet (tube OD 6)
- D Lubricant outlet (tube OD 6)
- P Lubricant inlet (tube OD 10)
- R Metered volume adjustment (max. stroke: 26 mm)

Number of elements (outlets)						
	1	2	3	4	5	6
A	95	125	155	185	215	245
B	62	92	122	152	182	212

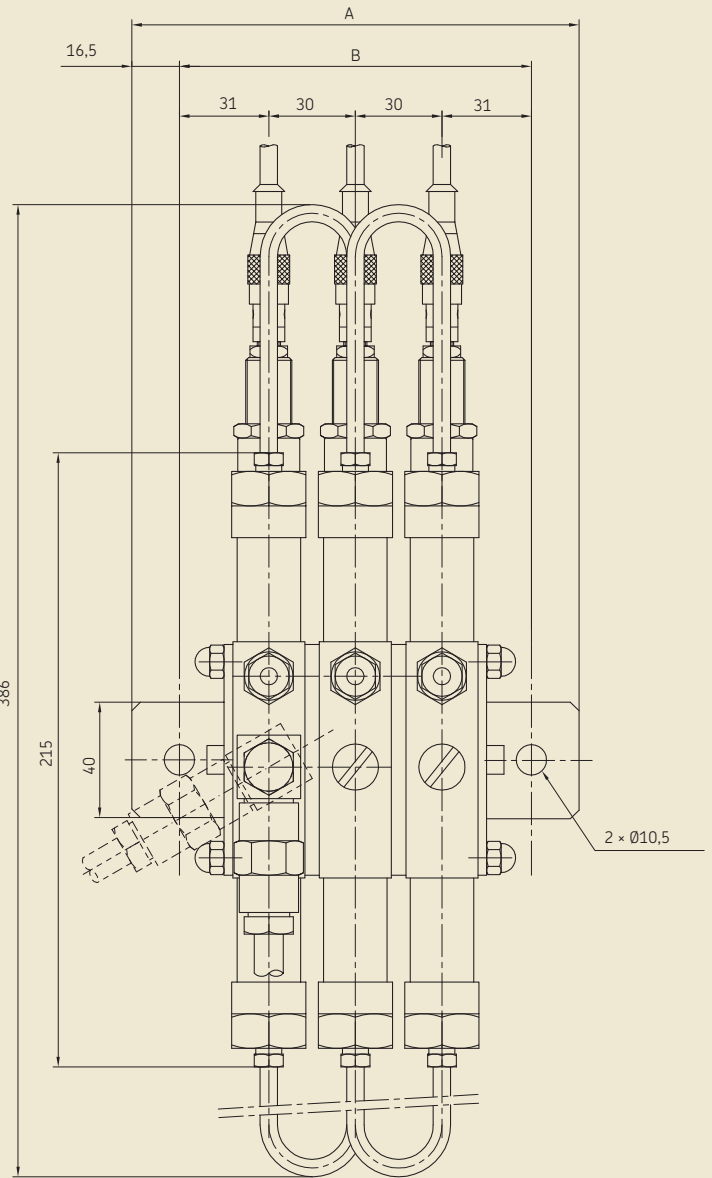
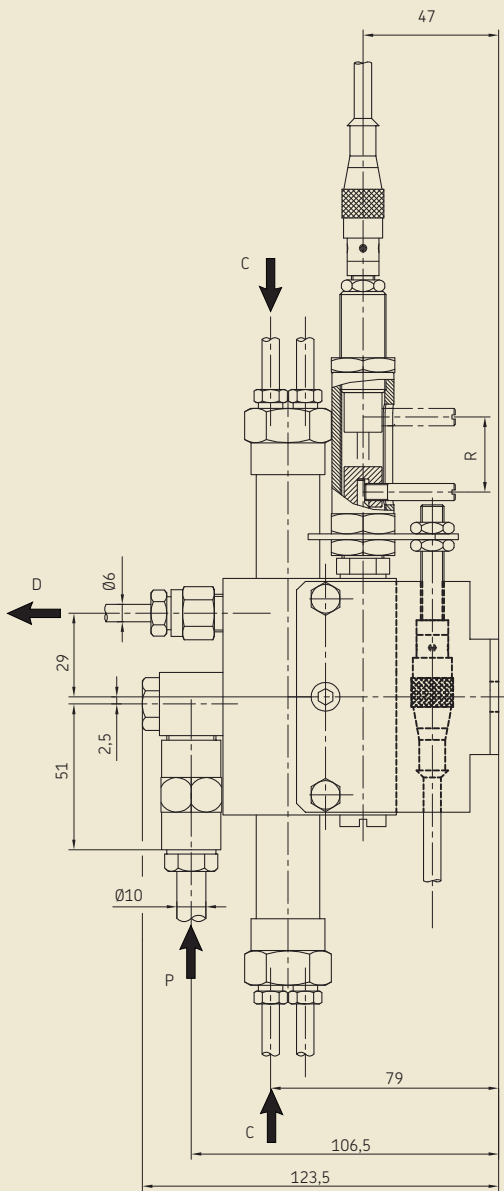

- C Air inlet (tube OD 6)
- D Lubricant outlet (tube OD 6)
- P Lubricant inlet (tube OD 10)
- R Metered volume adjustment (max. stroke: 26 mm)

Number of elements (outlets)						
	1	2	3	4	5	6
A	95	125	155	185	215	245
B	62	92	122	152	182	212

Order No.: 1-4202-EN

Subject to change without notice! (04/2009)

Important product usage information

All products from SKF may be used only for their intended purpose as described in this brochure and in any instructions. If operating instructions are supplied with the products, they must be read and followed.

Not all lubricants are suitable for use in centralized lubrication systems.

SKF does offer an inspection service to test customer supplied lubricant to determine if it can be used in a centralized system. SKF lubrication systems or their components are not approved for use with gases, liquefied gases, pressurized gases in solution and fluids with a vapor pressure exceeding normal atmospheric pressure (1013 mbars) by more than 0,5 bar at their maximum permissible temperature.

Hazardous materials of any kind, especially the materials classified as hazardous by European Community Directive EC 67/548/EEC, Article 2, Par. 2, may only be used to fill SKF centralized lubrication systems and components and delivered and/or distributed with the same after consulting with and receiving written approval from SKF.

Further brochures

1-9201-EN Transport of Lubricants in Centralized Lubrication Systems

This brochure was presented by:

® SKF is a registered trademark of the SKF Group.

© SKF Group 2009

The contents of this publication are the copyright of the publisher and may not be reproduced (even extracts) unless prior written permission is granted. Every care has been taken to ensure the accuracy of the information contained in this publication but no liability can be accepted for any loss or damage whether direct, indirect or consequential arising out of the use of the information contained herein.

