

# PTEX extruder pumps

Pneumatic extruder pump for drums of grease up to NLGI grade 2



The PTEX extruder pumps are pneumatically actuated pumps designed to deliver lubricant under pressure to lubrication installations.

The extruder pumps suck up the lubricant – grease from NLGI grade 000 to 2 – directly in drums of large capacity (25 kg to 200 kg) and deliver it under pressure (up to 400 bars according to the type of the pneumatic pump) to automatic lubrication installations (progressive centralized lubrication, dual-line lubrication, chain lubrication...).

The PTEX extruder pump also supplies with lubricant SKF DosaLub metering systems installed on industrial assembly lines.

## Advantages

- Full consumption of the lubricant contained in the drum (less than 0,5% of lubricant left)
- Extruder pump range for drums with different capacities – 25, 50 and 200 kg
- Transfer of fluid greases NLGI grade 000 to greases NLGI grade 2
- Tailor-made follower plate to perfectly meet the inner diameter of the drum

- The follower plate keeps the drum tight, no contamination of the lubricant
- Very easy to use
- Control is protected to prevent any accidental modification of the settings
- Very easy to replace the drum

## Function

Before using the extruder pump, PTEX, the drum has to be correctly positioned on the base of the pump according to the follower plate. If the drum is not correctly installed, the follower plate can not move downwards or the drum will not be tightened.

After opening the general air inlet valve, the user drives the cylinders of the extruder pump from the control console. The cylinders under pressure let the follower plate move downwards into the drum and press it against the lubricant.

After bleeding the extruder pump and drum, the user starts up the pneumatic pump from the control console. The pump sucks the

lubricant into the drum and delivers it to the connected centralized lubrication system.

The user can monitor the pump's operation and adjust the pump's pressure from the control console. During suction, the lubricant level falls in the drum. But under the effect of the cylinder pressure, the follower keeps moving downwards and stays pressed against the lubricant. The permanent contact between the lubricant and the follower plate optimizes the function of the pneumatic pump.

The position Reed switch (warning level) sends a warning signal when the follower plate gets closer to the bottom of the drum.

When the follower plate reaches the bottom of the drum, a pneumatic end switch switches off the air inlet of the cylinders and the pneumatic pump, and thus interrupts the operation of the pump (no air suction).

When the drum is empty, the user triggers the upward motion of the cylinders. But it also has to switch on the blowing air. This air is blown under the follower plate and will push it upwards.

### Note !

The extruder pump is delivered without drip pan.

## Control console

All control and monitoring functions of the PTEX extruder pump are on one control console. As a result, the PTEX extruder pump is very easy to operate. The functions are the following:

- control of the pneumatic pump function
- control of the follower plate function
- control of the blowing air inlet (upward motion of the follower plate)
- regulation and monitoring of the air pressure to let the follower plate move upwards
- regulation and monitoring of the air pressure to let the follower plate move downwards
- regulation and monitoring of the blowing air pressure (upward motion of the follower plate)
- regulation and monitoring of the air pressure for the actuation of the pump

See important product usage information on the back cover.  
See operating instruction 951-130-409.



- 1) Blowing air control switch – 2 positions (On / Off)
- 2) Blowing air pressure regulator with manometer
- 3) Air pressure regulator (follower plate upward motion) with manometer
- 4) Air pressure regulator (follower plate downward motion) with manometer
- 5) Follower plate control lever – 3 positions (up, stop, down)
- 6) Air inlet pressure regulator for the pneumatic pump
- 7) Air inlet manometer for the pneumatic pump
- 8) Pump control switch – 2 positions (On / Off)

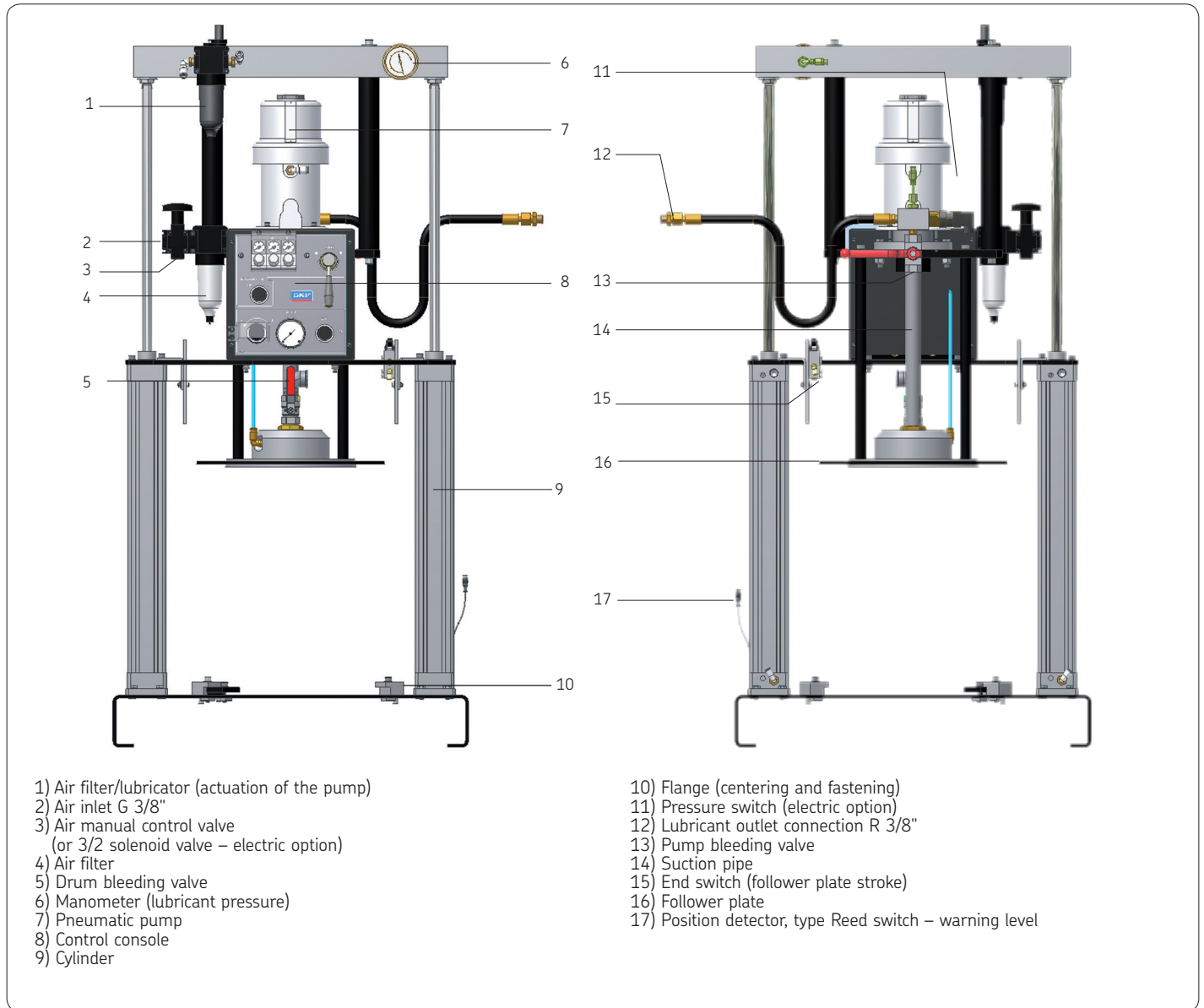

*PTEX extruder pump for 25 kg drum  
 (electric equipment)*

## Electric equipment

### Position Reed switch (warning level)

Every extruder pump PTEX has a position Reed switch. It detects the position of the cylinder when the follower plate comes down. It sends a signal to the user when the follower plate comes closer to the bottom of the drum (according to the adjustment by the user). When the user receives the signal, he has enough time to prepare a new drum and he avoids the risk of a production shutdown.

### Air solenoid valve (option)

The solenoid valve is mounted at the general air inlet of the extruder pump PTEX. It replaces the hand operated valve. With the solenoid valve, the user can control at a distance the general air inlet. This is a 3/2 way solenoid valve.

### Pressure switch (option)

The pressure switch is mounted at the pump lubricant outlet. It supplements the lubricant manometer and sends a signal when the minimal lubricant pressure has been reached.

Dimension 1

PTEX-25-S-B...

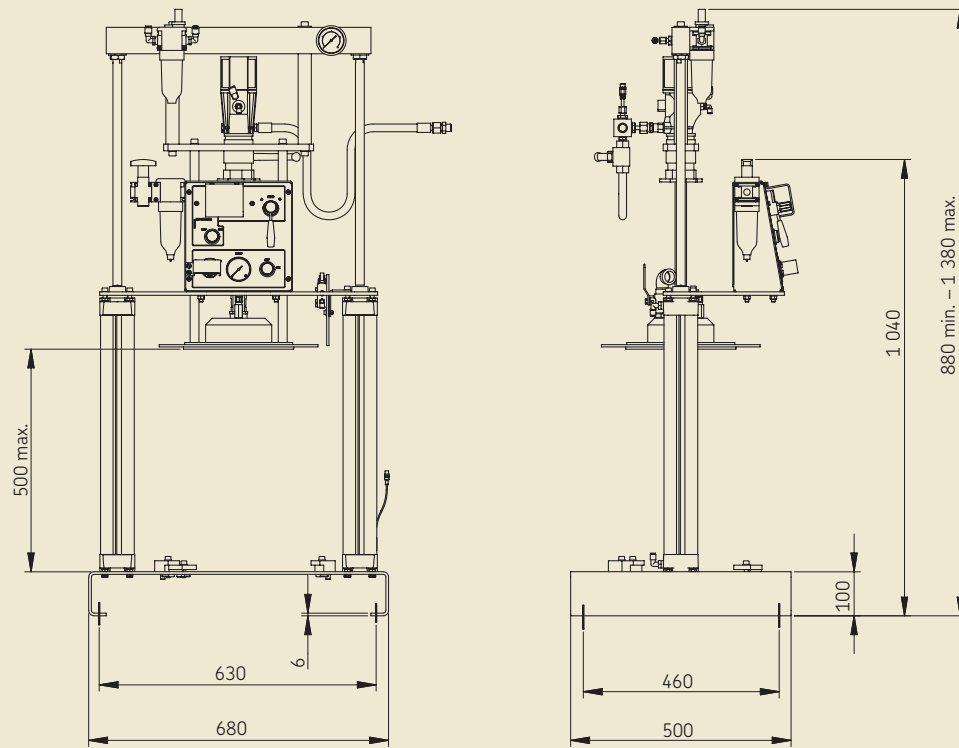

Dimension 2

PTEX-50-S-B...

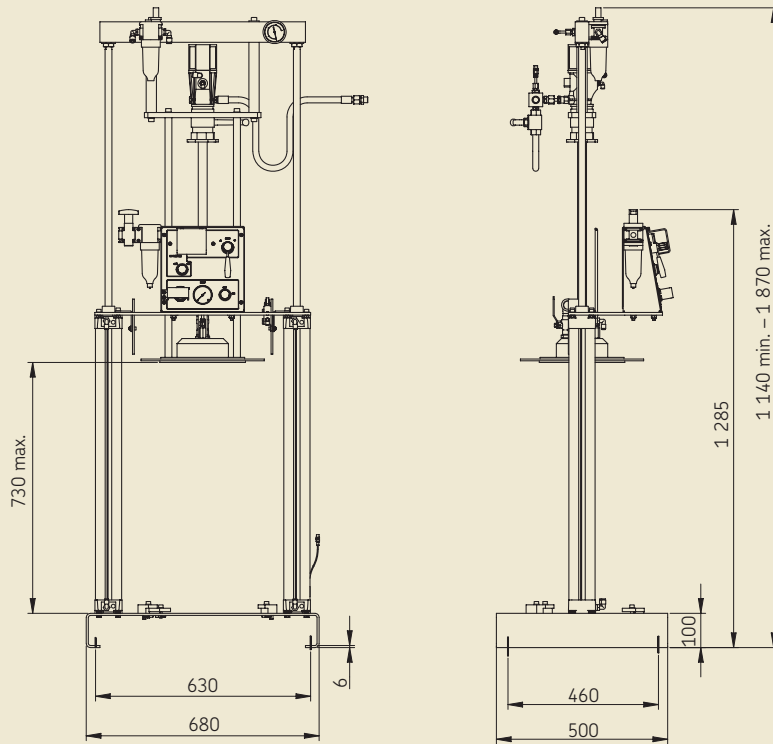

PTEX-200-S-A...

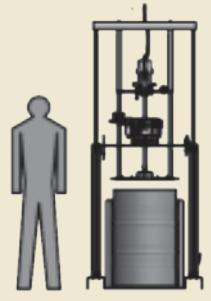
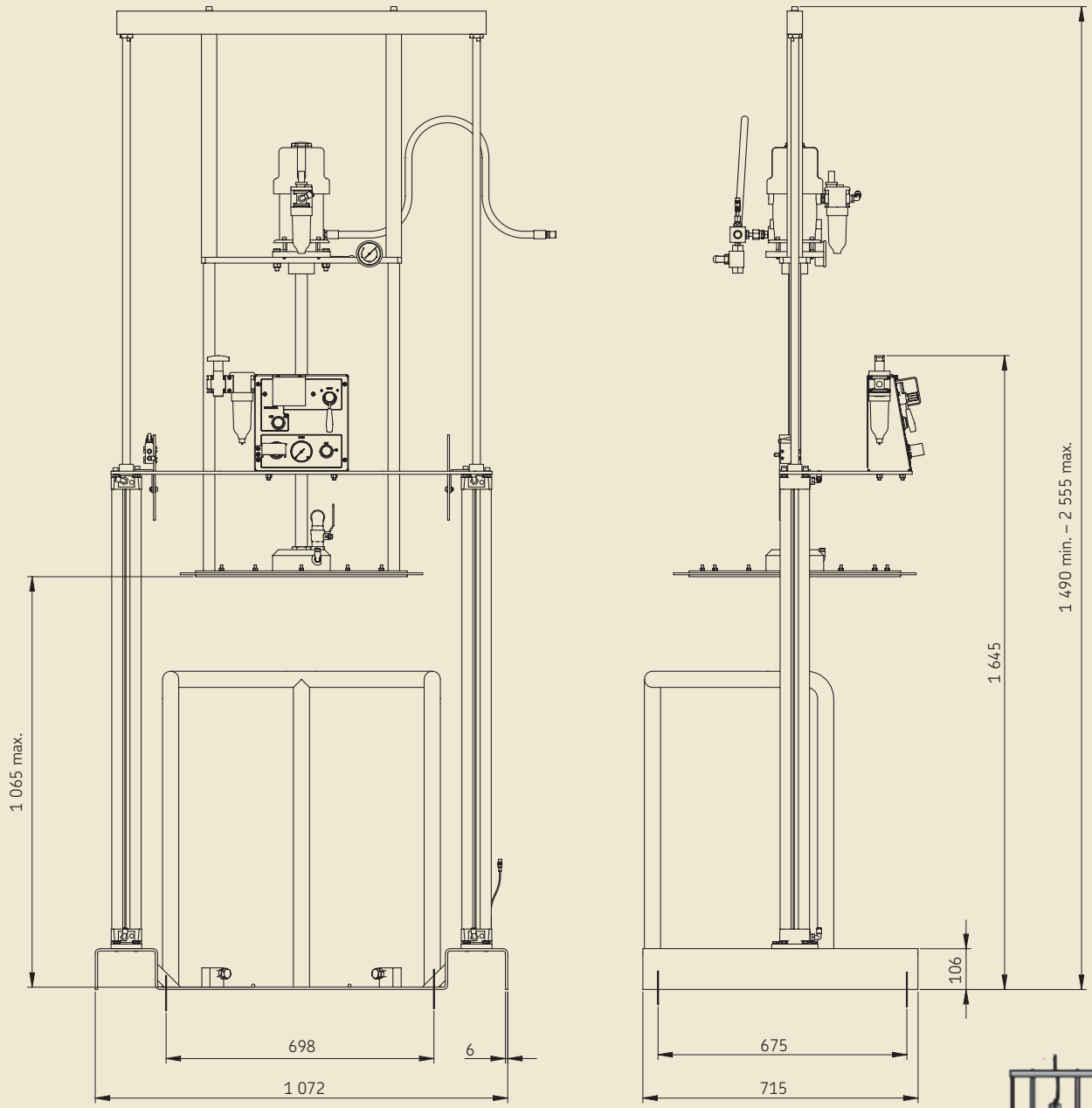

# Technical data

### Main data

Air consumption . . . . .	900 NI/min
Air inlet pressure . . . . .	3 to 8 bars
Pump ratio . . . . .	55:1
Pump delivery rate (at 6 bars)	
Pump A . . . . .	0,83 kg/min
Pump B . . . . .	0,5 kg/min
Lubricant . . . . .	greases NLGI grades 000 to 2
Operating temperature . . . . .	10 to 50 °C
Air inlet . . . . .	G 3/8

### Position detector, Reed switch type

Load voltage . . . . .	24 V DC
Max. load current . . . . .	5 to 40 mA
Visualization . . . . .	ON: LED on
Leakage current . . . . .	none
Operating time . . . . .	1,2 s
Operating temperature . . . . .	10 to 60 °C
Degree of protection . . . . .	IP67
Connector . . . . .	3-pin male connector, Ø M8
Cable . . . . .	vinyl Ø 3,4

Wiring diagram of the position detector

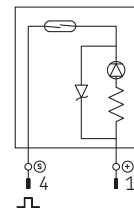

### Lubricant pressure switch

Max. operating voltage . . . . .	250 V AC
Degree of protection . . . . .	IP65
Setting range . . . . .	10 to 100 bars
Adm. pressure . . . . .	max. 300 bars
Electric connection . . . . .	PG9
Factory setting . . . . .	none

Wiring diagram of the pressure switch

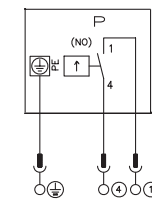

### General air solenoid valve

Type . . . . .	3/2 NC
Connection . . . . .	G 3/8
Electric connection . . . . .	PG9
Delivery rate . . . . .	2 700 NI/rmn
Operating pressure . . . . .	0 to 8 bars
Operating voltage . . . . .	24 V DC
Degree of protection . . . . .	IP65

Wiring diagram of the solenoid valve

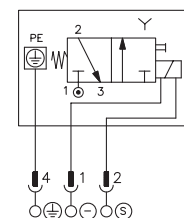

## PTEX extruder pump order number

PTEX extruder pumps							
Order No. <sup>1)</sup>	Drum capacity [kg]			Equipment		Pneumatic pump	
	25	50	200	standard	electric	Type A	Type B
PTEX-25-S-B	•			•			•
PTEX-25-E-B	•				•		•
PTEX-50-S-B		•		•			•
PTEX-50-E-B		•			•		•
PTEX-200-S-A			•	•		•	
PTEX-200-E-A			•		•	•	

<sup>1)</sup> When ordering a PTEX extruder pump, you have to complete the order number with a voltage key (see <sup>2)</sup> below) if you select the electric equipment at the same time, you have to indicate the inner diameter of the drum as well as the material of the wiper seal.

<sup>2)</sup> Voltage keys:  
**+924:** 24 V DC  
**+428:** 230 V 50/60 Hz  
**+429:** 115 V 50/60 Hz

### Important !

The **follower plate** is delivered with the extruder pump. To ensure pump reliability and tightness, the follower plate is manufactured in accordance with the pump's technical specifications. Therefore, when ordering the pump, you have to provide the inner diameter (in mm) and material for the lubricant drum you intend to use. At the same time, you have to select the **material of the wiper seal**, which best corresponds to the lubricant you intend to use. We are currently offering a FPM wiper seal. For any further technical information, please contact the SKF Service Center.

### Order example:

**PTEX-25-E-B+924, inner diameter of the drum 360, FPM wiper seal**

Extruder pump for a 25 kg drum (inner diameter 360 mm), electric option (operating voltage 24 V DC), and a FPM wiper seal.

**Order No.: 1-4009-EN**

Subject to change without notice! (04/2009)

**Important product usage information**

All products from SKF may be used only for their intended purpose as described in this brochure and in any instructions. If operating instructions are supplied with the products, they must be read and followed.

Not all lubricants are suitable for use in centralized lubrication systems.

SKF does offer an inspection service to test customer supplied lubricant to determine if it can be used in a centralized system. SKF lubrication systems or their components are not approved for use with gases, liquefied gases, pressurized gases in solution and fluids with a vapor pressure exceeding normal atmospheric pressure (1013 mbars) by more than 0,5 bar at their maximum permissible temperature.

Hazardous materials of any kind, especially the materials classified as hazardous by European Community Directive EC 67/548/EEC, Article 2, Par. 2, may only be used to fill SKF centralized lubrication systems and components and delivered and/or distributed with the same after consulting with and receiving written approval from SKF.

**Further brochures**

1-9201-EN Transport of Lubricants in Centralized Lubrication Systems

**This brochure was presented by:**

® SKF is a registered trademark of the SKF Group.

© SKF Group 2009

The contents of this publication are the copyright of the publisher and may not be reproduced (even extracts) unless prior written permission is granted. Every care has been taken to ensure the accuracy of the information contained in this publication but no liability can be accepted for any loss or damage whether direct, indirect or consequential arising out of the use of the information contained herein.

