

Electromagnetic pump PE

For the lubrication of floor or overhead conveyors

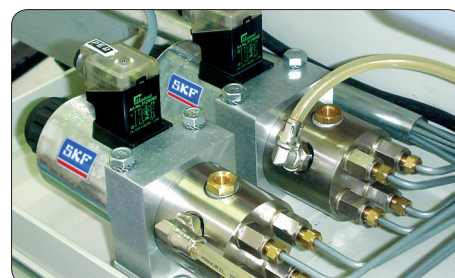

- Robust construction, long service life and modular design
- Oil projection via special spray nozzles to lubrication points
- Oil supply for oiling-brushes
- For oils with an effective viscosity up to 1 000 mm²/s
- Pump with 2, 3, 4 or 6 lubricant outlets
- Volumetric metering
- 3 flow rates: 20, 40 or 60 mm³/per stroke and outlet

PE-4-...

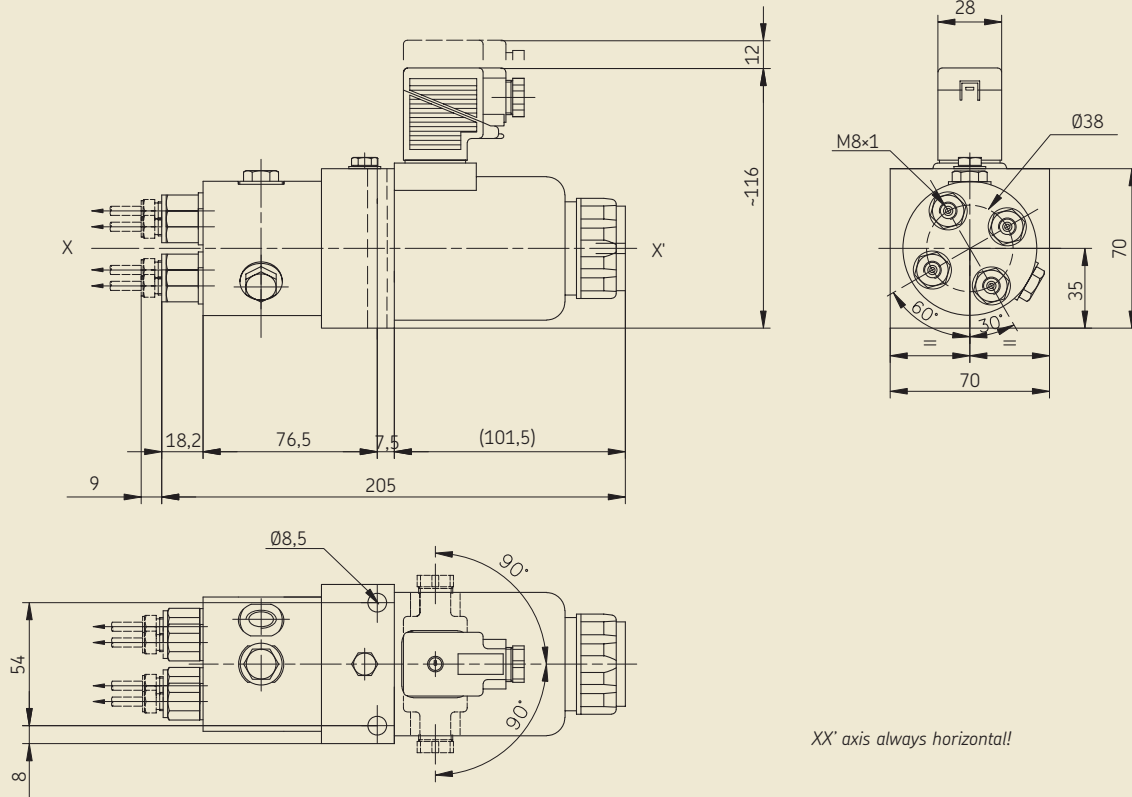

Design

The electromagnetic pump PE consists of a housing, a rotatable (-90°, 0°, +90°) mounting flange, an electric connector and an electromagnet that acts on the plunger. The plunger moves the pumping pistons with the help of a barrel centered in the pump's housing. A return spring pulls each piston back into its initial position. The PE pump can supply 2, 4 or 6 outlet ports. Each outlet port is equipped with a check valve.

Oil is fed directly from the lubricant reservoir into the intake chamber of the pump. The pump is vented by an opening.

Power is supplied to the pump via a swiveling connector – the signal light lights up when the power is on. DC or AC current supply. Alternating current can be rectified with a diode bridge.

The pump can be operated by hand at any time or when there is a power failure.

Application example

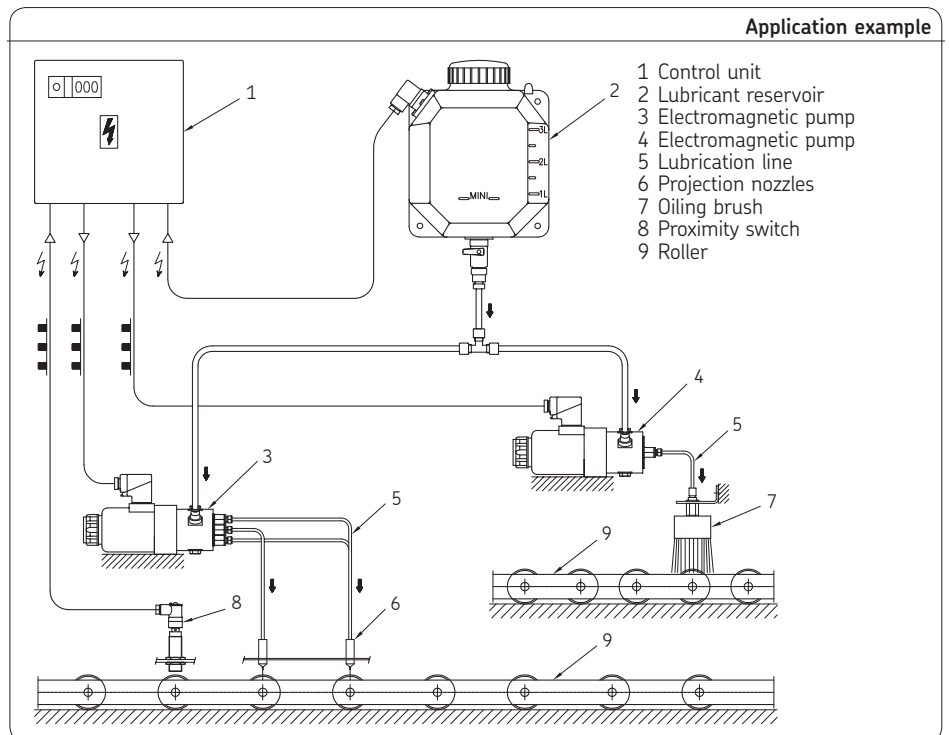

See important product usage information on the back cover.
See operating instruction 951-130-403.

Electromagnetic pump PE

Order information

Electromagnetic pump PE*)

Order No.**) (**))	Number of outlets	Flow rate per outlet
PE-2-20	2	20
PE-2-40	2	40
PE-2-60	2	60
PE-3-20	3	20
PE-3-40	3	40
PE-3-60	3	60
PE-4-20	4	20
PE-4-40	4	40
PE-4-60	4	60
PE-6-20	6	20
PE-6-40	6	40
PE-6-60	6	60

*) The electric connector is delivered with the pump PE

) Please indicate the voltage key when ordering: **+428 for 230 V AC, 50/60 Hz, **+429** for 115 V AC, 50/60 Hz, **+924** for 24 V DC

Order example:
PE-6-60+924 – PE pump with 6 outlets, flow rate 60 mm³ per stroke and outlet, power 24 V DC

Technical data

Delivery pressure	< 100 bars
Inlet pressure	0,01 < P < 0,5 bar
Flow rate	20, 40 or 60 mm ³ /stroke
Service temperature	-20 to +60 °C
Working frequency	≤ 2 strokes/s
Mechanical life	20 × 10 ⁶ cycles max.
Lubricant	mineral oil or synthetic oil, no additives, < 1 000 mm ² /s
Effective viscosity	< 1 000 mm ² /s
Seals	fluorocarbon (FPM)
Lubricant inlet	G 1/4 NF E 03-005 max. depth 8 mm
Lubricant outlet	M 8×1 acc. to NFR 954-03
Bleeding opening	G 1/4, plug H12
Weight (PE-6)	3 260 g

Electric

Direct current	24 V DC
or alternative current	115 V-50/60 Hz or 230 V-50/60 Hz
Intensity max.	4,5 A/24 VDC 1 A/115 V 0,55 A/230 V
Duty cycle	0,1 ≤ T ≤ 0,2 s
Duty ratio	40%
Electromagnet, power	105 W according to 93/68/EWG CE / 73/23/EWG low voltage.
Type of enclosure (screw-in connector)	IP 65
Connector	according to DIN 43 650

Electric connector wiring

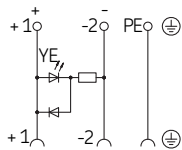

Wiring diagram for 24 V DC pump without integrated bridge rectifier and with LED

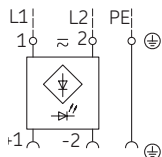

Wiring diagram for 115 and 230 V AC pump with integrated bridge rectifier and LED

Note

Operation with projection nozzles

Metallic tubing $\varnothing 4 \times 0,7$, as short as possible, length max. 3 m. Avoid using any connectors, banjo fittings and so on between the pump outlet port and the nozzle. They could impede the oil flow.

Operation with oiling brushes

Metallic or polyamide tubing $\varnothing 4 \times 0,75$, length max. 20 m.

Notice

Unused pump lubricant outlets shall not be closed! It could jam the function of the pump.

Cycle switch

The electromagnetic pump PE may be equipped with an inductive proximity switch in order to monitor the proper functioning of the pump.

Order No. PE-2016

Cycle switch

Type	inductive proximity switch PNP
Function	3 wires – when the pump is actuated, the contact opens
Operating voltage	NO
Nominal sensing distance (Sn)	10 to 30 V DC
Housing	1,5 mm
Connector	VA-T, IP67
	M 12×1

PE-2016

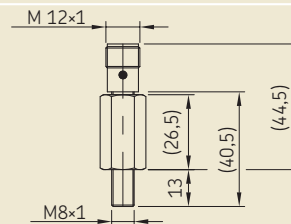

PE-2016 wiring diagram

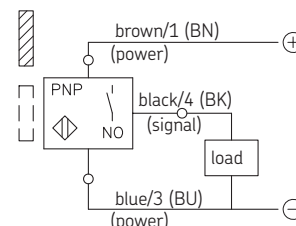

Order No.: 1-4003-EN

Subject to change without notice! (04/2009)

Important product usage information

All products from SKF may be used only for their intended purpose as described in this brochure and in any instructions. If operating instructions are supplied with the products, they must be read and followed.

Not all lubricants are suitable for use in centralized lubrication systems.

SKF does offer an inspection service to test customer supplied lubricant to determine if it can be used in a centralized system. SKF lubrication systems or their components are not approved for use with gases, liquefied gases, pressurized gases in solution and fluids with a vapor pressure exceeding normal atmospheric pressure (1013 mbars) by more than 0,5 bar at their maximum permissible temperature.

Hazardous materials of any kind, especially the materials classified as hazardous by European Community Directive EC 67/548/EEC, Article 2, Par. 2, may only be used to fill SKF centralized lubrication systems and components and delivered and/or distributed with the same after consulting with and receiving written approval from SKF.

Further brochures

1-9201-EN Transport of Lubricants in Centralized Lubrication Systems

This brochure was presented by:

® SKF is a registered trademark of the SKF Group.

© SKF Group 2009

The contents of this publication are the copyright of the publisher and may not be reproduced (even extracts) unless prior written permission is granted. Every care has been taken to ensure the accuracy of the information contained in this publication but no liability can be accepted for any loss or damage whether direct, indirect or consequential arising out of the use of the information contained herein.

