

Dual-Line Distributor

Product series 546

For oil and grease
For use in SKF DuoFlex Dual-line centralized lubrication systems



Application

Dual-line distributors are used in SKF DuoFlex dual-line centralized lubrication systems for greases up to NLGI Grade 3 with a worked penetration $> 220 \frac{1}{10}$ mm and for oils classified under ISO VG that have an operating viscosity greater than 50 mm²/s.

Advantages

- Low pressure losses due to large housing bores, which allows multiple distributors to be arranged in sequence
- Three sizes, continuously adjustable:
 - 0 - 0.5 cm³/stroke
 - 0 - 1.5 cm³/stroke
 - 0 - 5.0 cm³/stroke
- Compact construction for one to eight outlets available
- With fixed metering screws available on request
- Simple consolidation of outlets (doubling of metered quantity). Attachment of piston detectors for electrical function monitoring, makes retrofitting possible at any time
- Sealless fits for metering and control pistons provide sturdy and durable technology, especially under difficult operating conditionsmax.
- Operating pressure of 400 bars results in reliable lubrication of feeders
- Basic design in galvanized steel, optionally available in stainless steel (1.4301)

General Information

In contrast to single-line or progressive systems, dual-line systems are designed with two simultaneous feed lines.

A complete lubrication cycle consists of two half cycles, with the feed pump (1) applying pressure consecutively to main feed line 1, then 2.

A changeover valve (2) is required for control and a discharge pressure switch (3) is required for monitoring each completed half cycle.

Please note!

See important product usage information on the back cover.

Lubrication interval process in full cycle

During the lubrication break, the metering and control pistons are located in their respective end positions.

The following description of the process relates to the left end position.

First half cycle

As soon as pressure is applied to main feed line 1 by the change-over of the dual-line system and main feed line 2 is simultaneously relieved, the control piston and then the metering piston move to their respective right end positions. This pushes the lubricant pressed out of the metering piston through the control piston's ring groove to the right outlet. The quantity of lubricant pressed out of the control piston releases into main feed line 2. The lubricant pressure in main feed line 1 is retained until change-over of the dual-line system is actuated.

Second half cycle

After change-over is actuated, main feed line 2 is pressurized and main feed line 1 is relieved during the second half cycle.

The control piston and then the metering piston are now moved back into their initial position (left). This pushes the lubricant pressed out of the metering piston through the control piston's lower ring groove to the left outlet.

The quantity of lubricant pressed out of the control piston relieves into main feed line 1. The lubricant pressure in main feed line 2 is retained until change-over of the dual-line system is actuated again.

The metering piston in the standard version is equipped with a visual indicator pin, an adjusting screw for delivery volume 0 - 100% and a protective cap.

Lubricant distributors with fixed metering screws are recommended for extreme loads such as those with contamination, vibrations, etc.

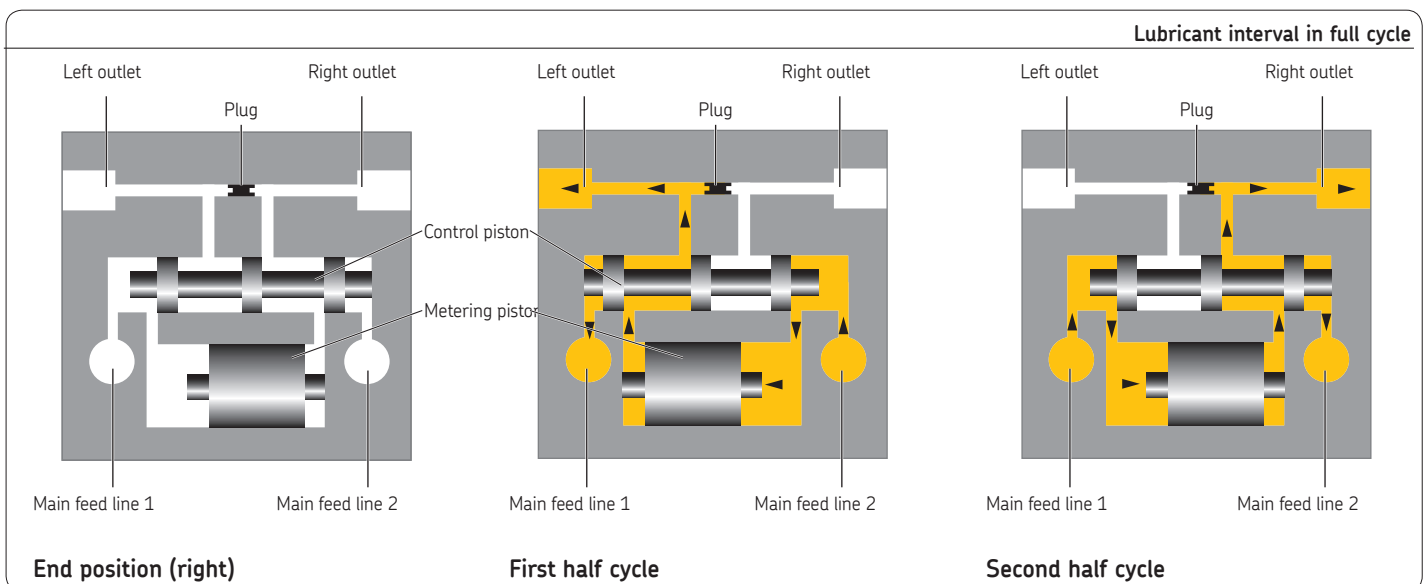

Function monitoring

The dual-line distributor can be monitored visually or electrically.

The distributor can be monitored visually using the indicator pin on each metering piston. The indicator pin is directly connected to the metering piston. This allows the function of the metering piston to be monitored visually. Electrical function monitoring is optional using a piston detector. To do this, the piston detector is screwed into the bore hole and actuated directly by the piston. This means the moving parts do not need to be sealed. Visual monitoring is not necessary on distributors with fixed metering volumes. Monitoring can be performed using the piston detector. Each pair of outlets is usually equipped with visual or electrical monitoring.

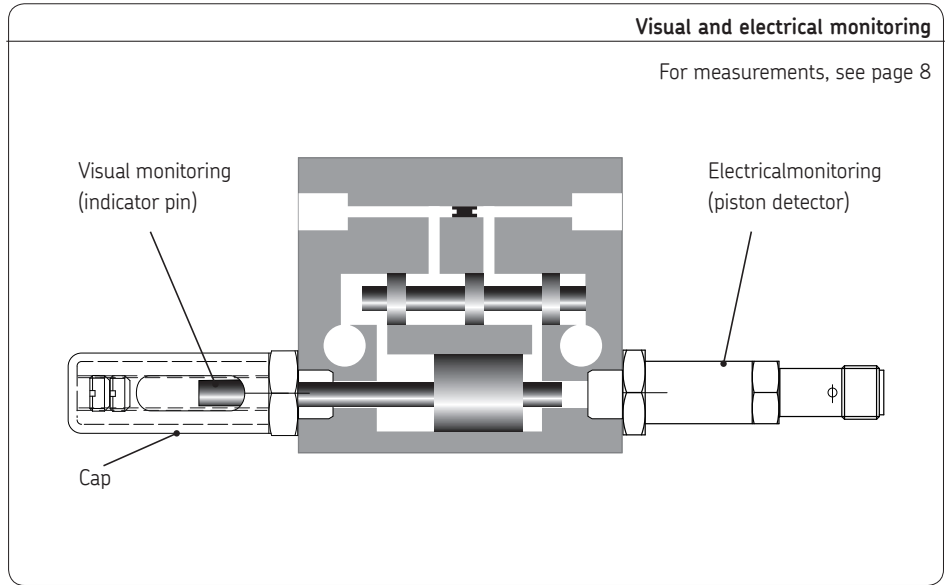

Consolidation of two outlets

Outlets need to be consolidated in case of applications with increased lubrication requirements or dual-line distributors with an uneven number of outlets. Removing the plug (hexagon socket WAF 3) allows the delivery rates for both opposite lubricant outlets to be consolidated into one outlet. The unused outlet needs to be closed using a screw plug with a washer.

Accessories	
Designation	Order no.
Screw plug with washer for consolidating 2 outlets	
G 1/4" steel, galvanized	466-416-001
G 1/4" stainless steel 1.4301	835-330-00

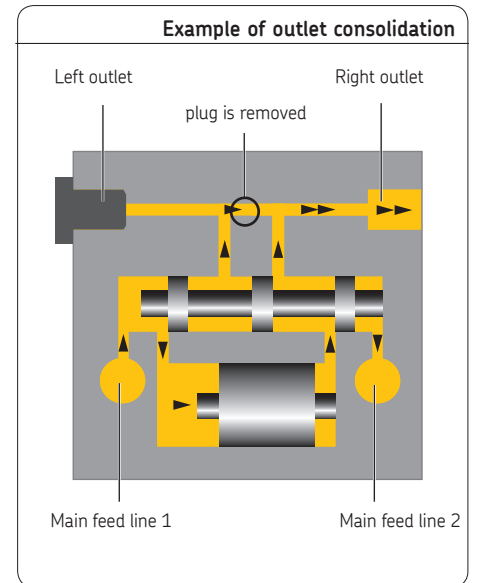

Dual-line distributor with indicator pin and adjustable metering volume, delivery rate up to 0.5 and 1.5 cm³/stroke for oil and grease



Technical Data

General

Type hydraulically controlled
 Mounting position.....discretionary ¹⁾
 Outlets 1 to 8 ²⁾
 Ambient temperature range - 25 to + 80 °C

Material

Distributor..... galvanized steel
 optional in stainless steel 1.4305

Hydraulic

Max. operating pressure:

Distributor without electrical monitoring400 bar
 Distributor with electrical monitoring..... 350 bar
 Volume per outlet and cycle, continuously adjustable ³⁾:

0.5 variant..... 0 - 0.5 cm³/stroke
 1.5 variant..... 0 - 1.5 cm³/stroke

Lubricant..... Greases up to NLGI Grade 3 and oils with operating viscosity ≥ 50 mm²/s based on mineral oil or synthetic oils, compatible with plastics, NBR elastomers, copper and copper alloys.

Worked penetration ≥ 220 ^{1/10} mm (up to NLGI Grade 3)

Sealing material..... NBR

Cap optionally plastic, aluminum or stainless steel

- 1) In case of an installation on movable machine parts or in case of strong vibrations, the piston position of the distributor must not match the direction of movement of the machine part.
- 2) Outlets need to be consolidated if there are uneven numbers of outlets (see page 3)
- 3) See page 10 for continuous adjustment of the metered quantity; the distributor is set to maximum metering quantity at the factory.

Dual-line distributor with adjustable metering volume

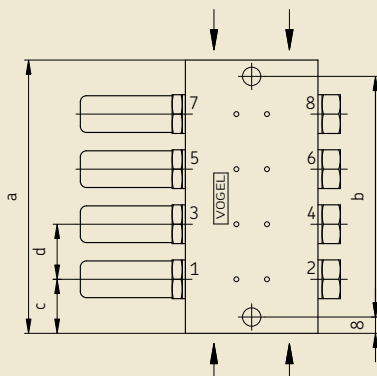
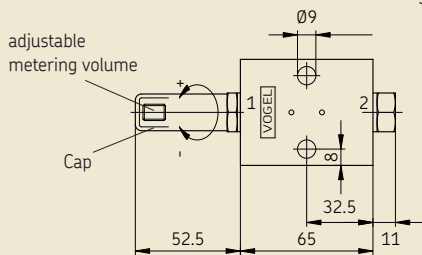
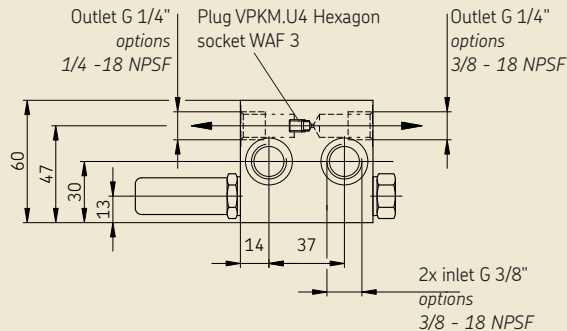

Dimensions

Number of outlets	Dim. a [mm]	Dim. b [mm]	Dim. c [mm]	Dim. d [mm]	Comp. weight [kg]
2	44.6	30.6	22.3	-	1.41
4	76.5	62.5	22.3	31.9	2.75
6	108.4	94.4	22.3	31.9	4.09
8	140.3	126.3	22.3	31.9	5.43

Dual-line distributor with fixed metering volume, delivery rate up to 0.5 and 1.5 cm³/stroke for oil and grease



Technical Data

General

For further technical data, see page 4

Volume per outlet and cycle, fixed ¹⁾:

0.5 variant. options 0.125 / 0.25 / 0.375 / 0.5 cm³/stroke

1.5 variant. options 0.37 / 0.75 / 1.12 / 1.5 cm³/stroke

1) Delivery rate is fixed at 25%, 50%, 75% or 100% of the maximum volume; see the key to order codes on page 11.

Dual-line distributor with fixed metering volume

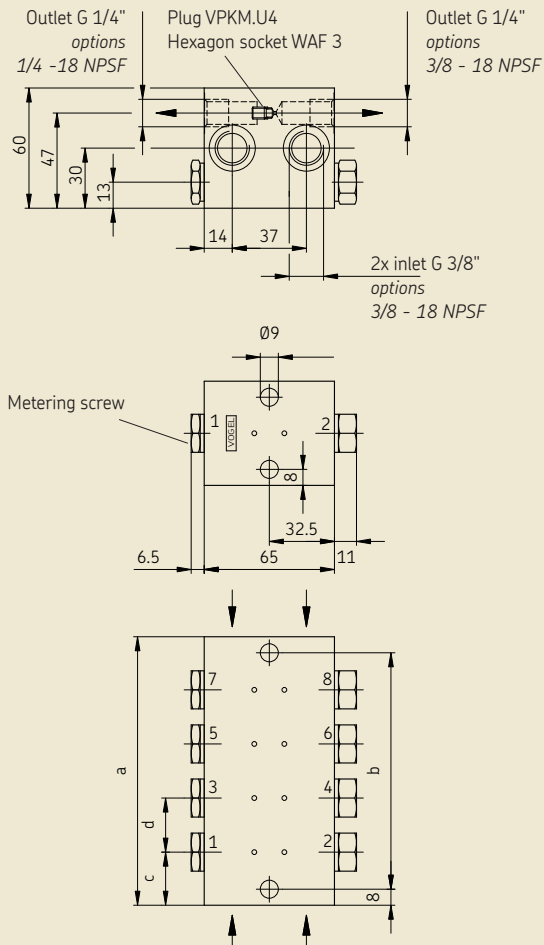

Spare parts

Designation	Volume	Order no.
Metering screws, stainless steel		
for variant with 0,5 cm³/stroke	cm³/stroke	
25%	0.125	44-1821-3004
50%	0.25	44-1821-2987
75%	0.375	44-1821-2986
100%	0.5	44-1821-2985
for variant with 1.5 cm³/stroke		
25%	0.37	44-1821-2981
50%	0.75	44-1821-2982
75%	1.12	44-1821-2983
100%	1.5	44-1821-2984
O-ring per metering screw		WVN501-12x2.5

Dual-line distributor with indicator pin and adjustable metering volume, delivery rate up to 5 cm³/stroke for oil and grease

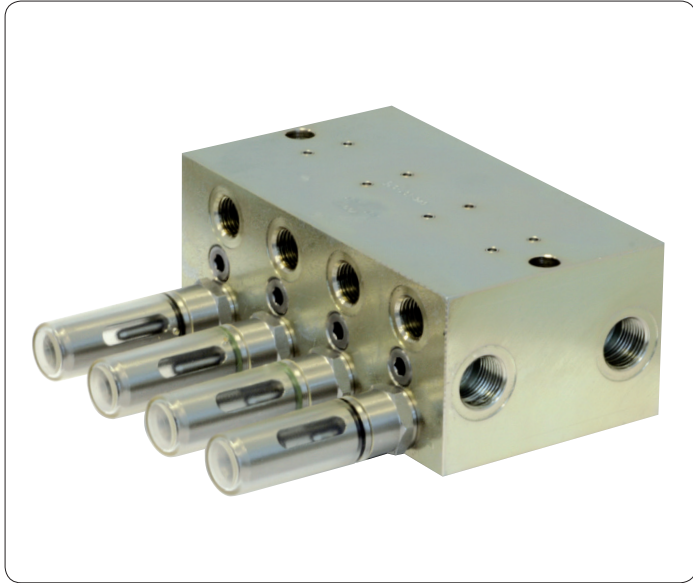

Dual-line distributor with adjustable metering volume

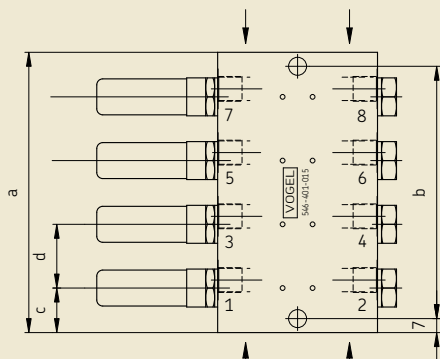
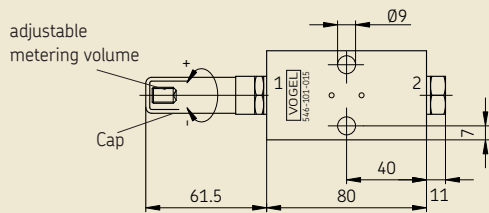
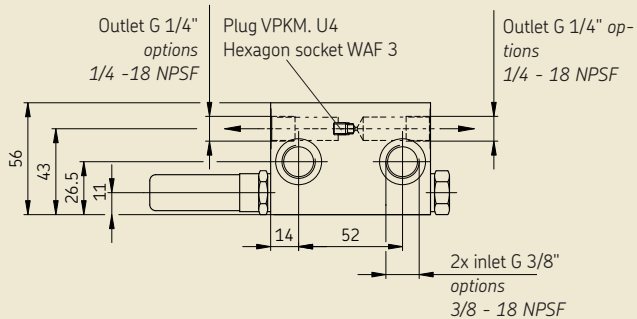

Technical Data

General

Type hydraulically controlled
 Mounting position discretionary¹⁾
 Outlets 2 to 8 Ambient
 Temperature range - 25 to + 80 °C

Material

Distributor galvanized steel
 optional in stainless steel 1.4301
 HydraulicMax. operating pressure:
 Distributor without electrical monitoring 400 bar
 Distributor with electrical monitoring 350 bar
 Volume per outlet and cycle,
 continuously adjustable ²⁾ 0 - 5 cm³/stroke
 Lubricant Greases up to NLGI Grade 3 and oils with
 operating viscosity ≥ 50 mm²/s based on mineral
 oil or synthetic oils, compatible with plastics,
 NBR elastomers, copper and copper alloys.

Worked penetration ≥ 220 ¹/₁₀ mm (up to NLGI Grade 3)
 Sealing material NBR
 Cap optionally plastic, aluminum or stainless steel

- 1) In case of an installation on movable machine parts or in case of strong vibrations, the piston position of the distributor must not match the direction of movement of the machine part.
- 2) Outlets need to be consolidated if there are uneven numbers of outlets (see page 3)
- 3) See page 10 for continuous adjustment of the metered quantity; the distributor is set to maximum metering quantity at the factory.

Dimensions

Number of outlets	Dim. a [mm]	Dim. b [mm]	Dim. c [mm]	Dim. d [mm]	Comp. weight [kg]
2	44.6	30.6	22.3	-	1.41
4	76.5	62.5	22.3	31.9	2.75
6	108.4	94.4	22.3	31.9	4.09
8	140.3	126.3	22.3	31.9	5.43

Dual-line distributor with fixed metering volume, delivery rate up to 5 cm³/stroke for oil and grease



Technical Data

General

For further technical data, see Technical Data on page 6

Volume per outlet and cycle, fixed ¹⁾:

5 variant options 1.25 / 2.5 / 3.75 / 5 cm³/stroke

1) Delivery rate fixed at 25%, 50%, 75% or 100% of the maximum volume; see the key to order codes on page 11.

Spare parts

Designation	Volume	Order no.
Metering screws, stainless steel		
for variant with 5 cm³/stroke	cm³/stroke	
25%	1.25	44-1821-3008
50%	2.5	44-1821-3007
75%	3.75	44-1821-3006
100%	5	44-1821-3005
O-ring per metering screw		WVN501-12x2.5

Dual-line distributor with fixed metering volume

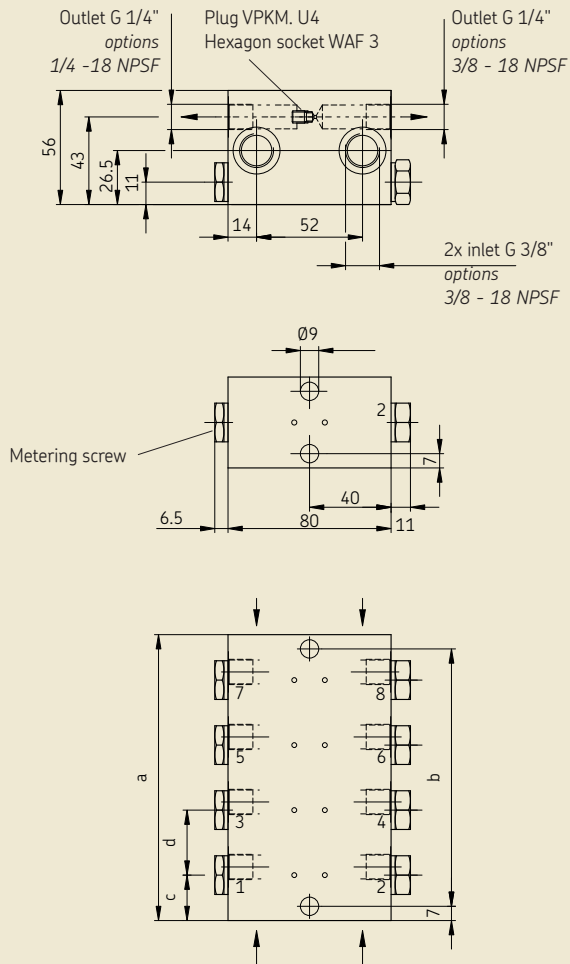

Piston detector for dual-line distributors



Technical Data

General Information

Piston detector 3-pin (short-circuit proof, intermittent and protected against polarity reversal, NC contact PNP)

Function NC contact

Operating voltage 10 to 36 V DC

Operating temperature -25 to +80 °C

Current-carrying capacity max. 100 mA

Power consumption < 15 mA

Switching state display LED yellow

Protection class IP 67

EMV-EMC EN 60947-5-2

Safety class III - protective extra-low voltage

Housing material stainless steel 1.4571

Piston detector

For further measurements, see pages 4 and 6

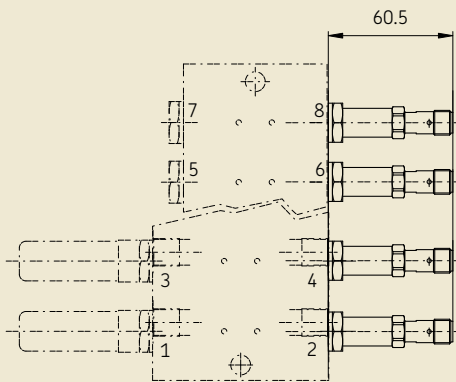
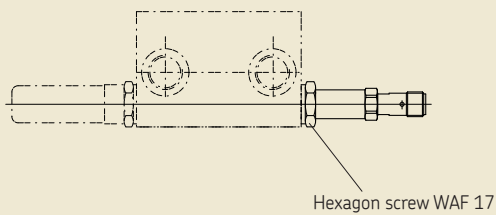

Connection diagram

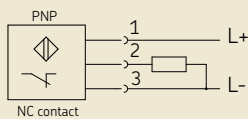

Pin	Function	Conductor coloring
1	(+)	brown (BN)
2	output	white (WH)
3	(-)	blue (BU)

Spare parts

Designation	Order no.
Piston detector	
for 0.5 and 1.5 cm ³ /stroke	177-300-130
for 5.0 cm ³ /stroke	177-300-131
O-ring for piston detector	WVN501-12x2.5
Cable socket, straight, without cable	179-990-371
Cable socket, angled, without cable	179-990-372
Cable socket, straight, with cable (5 m)	179-990-600
Cable socket, angled, with cable (5 m)	179-990-601

Note

The cable socket is ordered separately. For technical data, please refer to brochure no. 1-1730-EN, "Electrical Plug-In Connections".

Subsequent installation of a piston detector

Piston detectors are used for electrical stroke monitoring of the distributor function.

Their compact, vibration-proof and maintenance-free construction makes them especially suitable for monitoring dual-line distributors.

The optional piston detector is attached using an O-ring. Additional attachments are not necessary.

Procedure

Note!

If the piston detector is later installed in a dual-line distributor, the following instructions and precautions and all corresponding safety regulations (see the Operating Instructions and local law) must be followed.

- Turn off the dual-line system

☞ The dual-line distributor in question must be in a depressurized state.

☞ **Warning! Potential burn risk!** Maximum lubricant temperature is 80°C. Exercise caution when handling lubricant.

- Loosen screw plug (1) of the distributor piston (2) and remove plug along with O-ring (3)
- Insert new O-ring (4) in the sealing ring of the piston detector (5)
- Carefully place the piston detector (5) on the distributor section (2) and attach it gently by hand
- ☞ While you tighten the piston detector (5) as follows, be sure that the cable socket connection (6) is not damaged or contaminated.
- Tighten the piston detector (5) using a torque wrench (WAF 19) at a torque of 5 N/m
- Place the cable socket (7) on the piston detector and attach it by hand

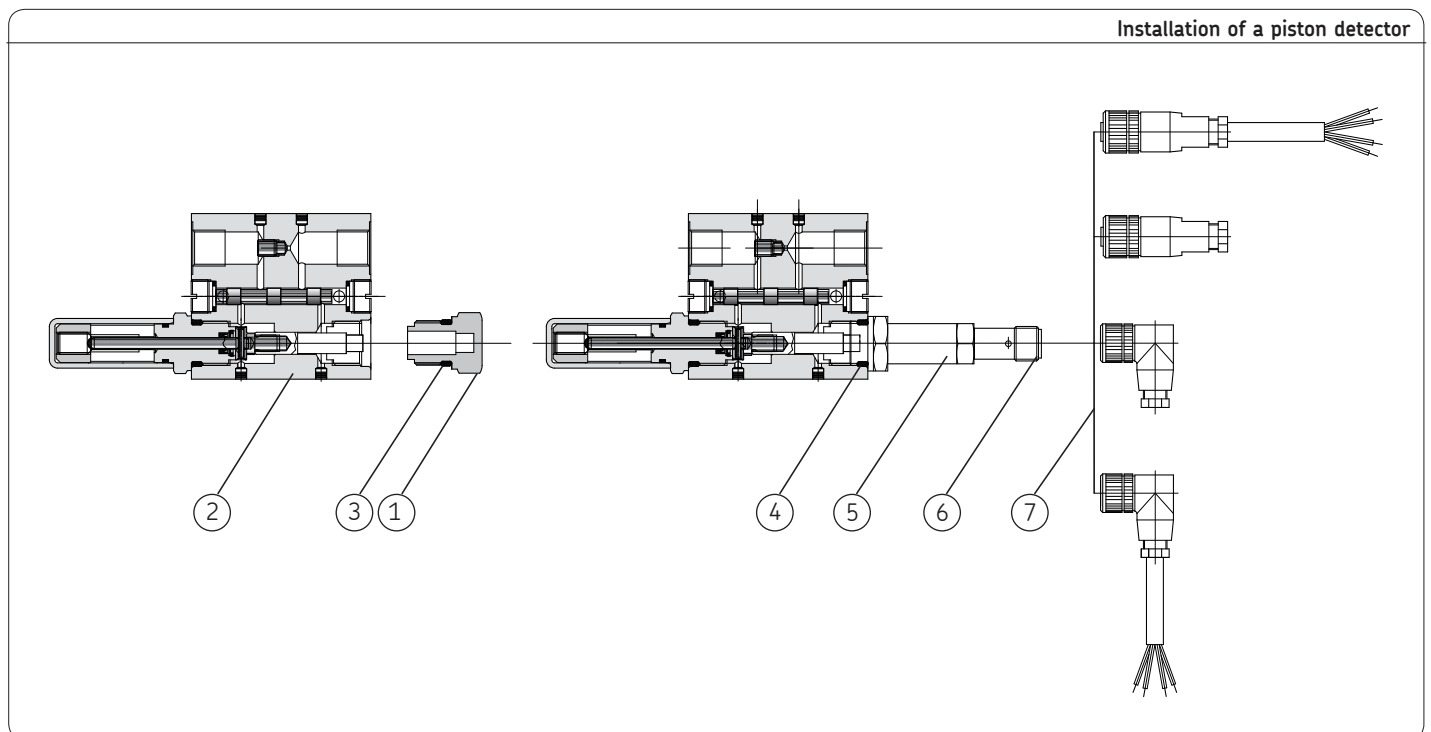

Changing metering volume on adjustable dual-line distributor

Setting the metered quantity:

on a distributor with a delivery rate of **0 to 0.5 cm³/stroke**, 1 revolution of the setting screw corresponds to a **0,06 cm³** change in metered quantity.

on a distributor with a delivery rate of **0 to 1.5 cm³/stroke**, 1 revolution of the setting screw corresponds to a **0.14 cm³** change in metered quantity.

on a distributor with a delivery rate of **0 to 5 cm³/stroke**, 1 revolution of the setting screw corresponds to a **0,16 cm³** change in metered quantity.

Dual-line distributors in three sizes (0.5, 1.5 and 5.0 cm³/stroke) are set to a maximum metered quantity when shipped.

Reducing the delivery rate:

- Remove cap
- Insert screwdriver in lock screw "C"
- Loosen and unscrew the lock screw
- Insert screwdriver in setting screw "B"
- Reduce the delivery rate by screwing in the setting screw clockwise

Increasing the delivery rate:

- Increase the delivery rate by unscrewing the setting screw counterclockwise
- ☞ Adjustments made to the metering piston apply to both outlets
- Position lock screw "C" and attach against setting screw "B"
- Attach cap

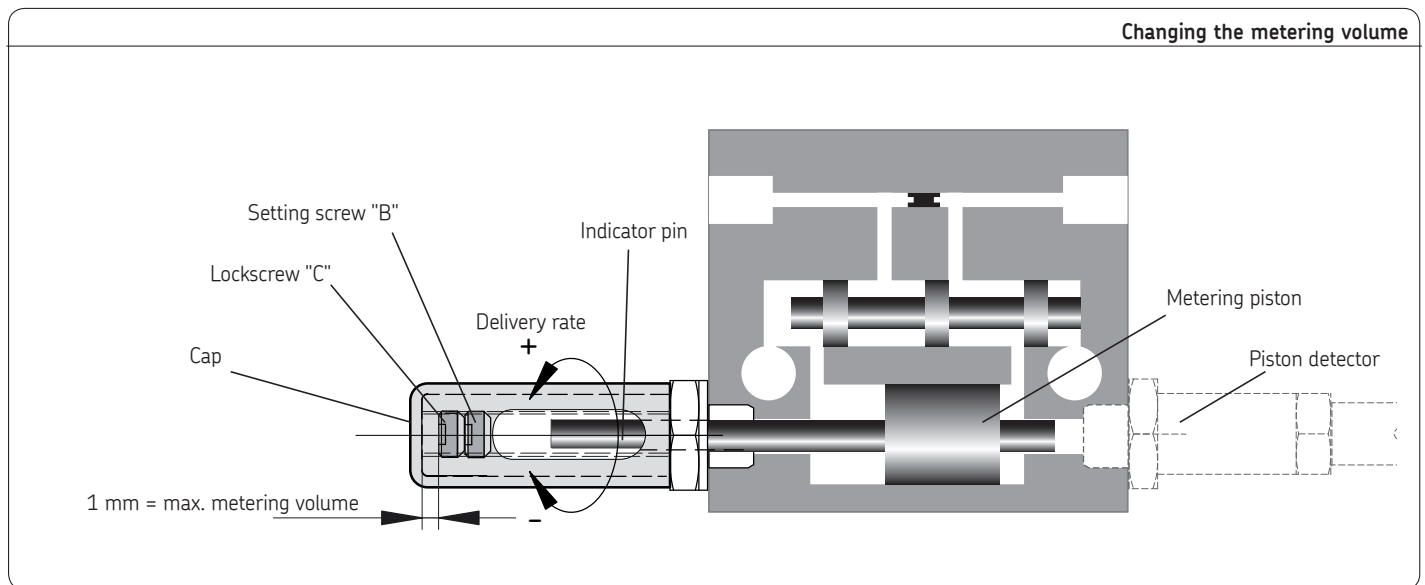

Accessories

Description	Order no.	Order no.
Screw union	Galvanized steel	Stainless steel 1.4571
Outlet G 1/4", tube diameter 6 mm	406-413W	406-413W-S3
Outlet G 1/4", tube diameter 8 mm	408-403W	408-403W-S3
Outlet G 1/4", tube diameter 10 mm	410-403W	410-403W-S3
Inlet G 3/8", tube diameter 10 mm	410-413W	410-413W-S3
Inlet G 3/8", tube diameter 12 mm	466-416-001	466-416-001-S3

Screw unions as per DIN 2353, light series, galvanized or stainless steel. See Accessories Catalog, order no. 1-0103, for DIN 2353 screw unions, heavy series.

Key to order codes

for fixed delivery rate

546 -4 01 - 0 12 - 4 3 2 1

for adjustable delivery rate

546 -4 01 - 0 12

Dual-line block feeder

- 546 = Inlets and outlets with inch thread
- 545 = Inlets and outlets with NPSF thread

Design/Number of outlets

- 1 = 1 part, 2 outlets
- 2 = 2 part, 4 outlets
- 3 = 3 part, 6 outlets
- 4 = 4 part, 8 outlets

Change version

Cap design

- 0 = plexiglass cap / without cap on distributor with fixed metering volume
- 1 = aluminum cap, anodized (only galvanized for steel)
- 2 = Stainless cap, (only for stainless steel)

Delivery rate, design, with and without piston detector

delivery rate up to 0,5 cm³/stroke

- 04 = steel, galvanized, without piston detector
- 09 = steel, galvanized, with piston detector
- 08 = stainless steel, without piston detector
- 10 = stainless steel, with piston detector

delivery rate up to 1,5 cm³/stroke

- 11 = steel, galvanized, without piston detector
- 12 = steel, galvanized, with piston detector
- 13 = stainless steel, without piston detector
- 14 = stainless steel, with piston detector

delivery rate up to 5.0 cm³/stroke

- 15 = steel, galvanized, without piston detector
- 18 = steel, galvanized, with piston detector
- 16 = stainless steel, without piston detector
- 17 = stainless steel, with piston detector

The following information is only required for fixed delivery rate

see pages 5 and 7

Delivery rate, outlets 1 and 2 set to:

- 1 = 25 % delivery rate
- 2 = 50 % delivery rate
- 3 = 75 % delivery rate
- 4 = 100 % delivery rate

Delivery rate, outlets 3 and 4 set to:

- Without code number = distributor has only 2 outlets
- 1 = 25 % delivery rate
- 2 = 50 % delivery rate
- 3 = 75 % delivery rate
- 4 = 100 % delivery rate

Delivery rate, outlets 5 and 6 set to:

- Without code number = distributor has only 4 outlets
- 1 = 25 % delivery rate
- 2 = 50 % delivery rate
- 3 = 75 % delivery rate
- 4 = 100 % delivery rate

Delivery rate, outlets 7 and 8 set to:

- Without code number = distributor has only 6 outlets
- 1 = 25 % delivery rate
- 2 = 50 % delivery rate
- 3 = 75 % delivery rate
- 4 = 100 % delivery rate

Examples for ordering dual-line distributors with adjustable delivery rate:

Dual-line block feeder with inch thread from series (546), 4 part with 8 outlets (4), change version (01), with plexiglass cap (0), with delivery rate up to 1.5 cm³/stroke, feeder housing made of galvanized steel with piston detector (12), has the following order number: **546-401-012**

Examples for ordering dual-line distributors with fixed delivery rate:

Dual-line block feeder with inch thread from series (546), 4 part with 8 outlets (4), change version (01), with plexiglass cap (0), with delivery rate up to 1.5 cm³/stroke, feeder housing made of galvanized steel with piston detector (12) and fixed delivery rate from outlet 1+2 = 100% (4), outlet 3+4 = 75% (3), outlet 5+6 = 50% (2), outlet 7+8 = 25% (1), has the following order number: **546-401-012-4321**

Order No. 1-0012-3-EN

Subject to change without notice! (07/2014)

Important product usage information

All products from SKF may be used only for their intended purpose as described in this brochure and in any instructions. If operating instructions are supplied with the products, they must be read and followed.

Not all lubricants are suitable for use in centralized lubrication systems. SKF does offer an inspection service to test customer supplied lubricant to determine if it can be used in a centralized system. SKF lubrication systems or their components are not approved for use with gases, liquefied gases, pressurized gases in solution and fluids with a vapor pressure exceeding normal atmospheric pressure (1013 mbars) by more than 0.5 bar at their maximum permissible temperature.

Hazardous materials of any kind, especially the materials classified as hazardous by European Community Directive EC 67/548/EEC, Article 2, Par. 2, may only be used to fill SKF centralized lubrication systems and components and delivered and/or distributed with the same after consulting with and receiving written approval from SKF.

Further brochures

1-0012-1-EN	Lubrication pumps for dual-line centralized lubrication systems
1-0012-2-EN	Hydraulic and electrical control units
1-0103-EN	Fittings and Accessories

SKF Lubrication Systems Germany GmbH

2. Industriestrasse 4 · 68766 Hockenheim · Germany
Tel. +49 (0)62 05 27-0 · Fax +49 (0)62 05 27-101
www.skf.com/lubrication

This brochure was presented by:

® SKF is a registered trademark of the SKF Group.

© SKF Group 2014

The contents of this publication are the copyright of the publisher and may not be reproduced (even extracts) unless prior written permission is granted. Every care has been taken to ensure the accuracy of the information contained in this publication but no liability can be accepted for any loss or damage whether direct, indirect or consequential arising out of the use of the information contained herein.

