

Centralized Lubrication Systems

Systems, Symbols

A centralized lubrication system performs the task of supplying individual lube points or groups of points with varying amounts of exactly metered lubricant from one central location to meet their different needs.

Oil and grease of NLGI grades 000 to 3 are used as the lubricant.

Care taken during the installation, start-up and maintenance of the central lubrication system will help to enhance the operating readiness and life of your machines. The central lubrication system must be given the same attention as all the other sophisticated equipment on a machine.

The many years of experience we have had in the field of central lubrication technology for machines and systems will allow us to help you solve the problems you encounter when planning and using such installations. Centralized lubrication systems are classified in accordance with their function and type of lubricant distribution.

We'll be happy to advise you.

Overview of centralized lubrication systems (based on DIN 24271)

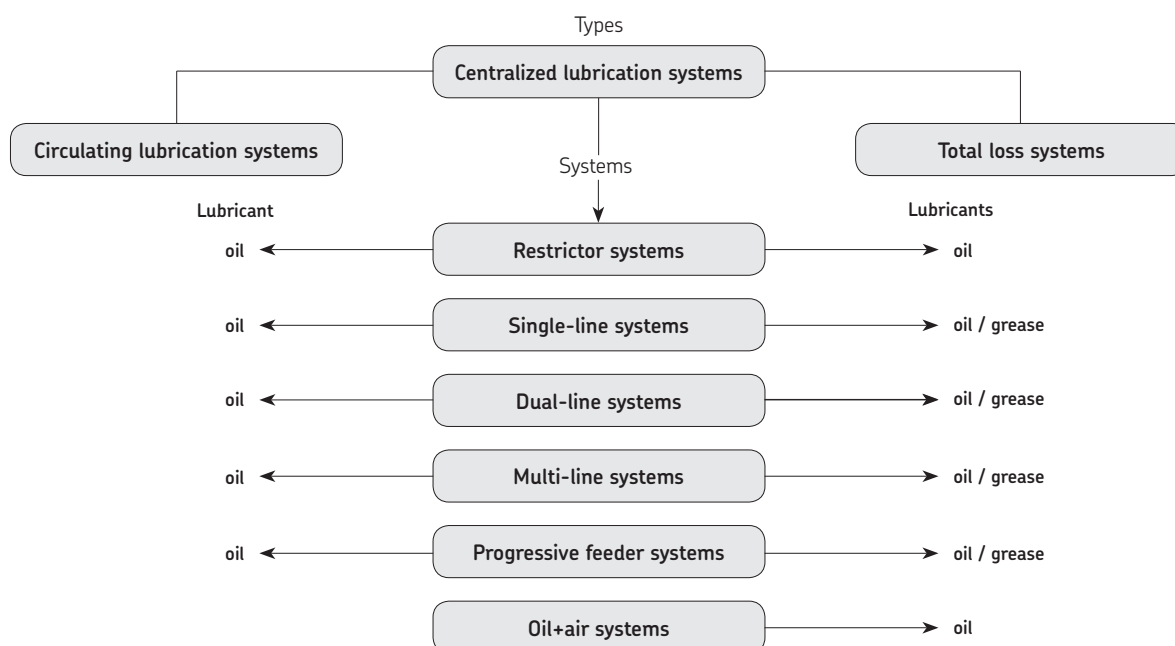

Single-line total loss lubrication system

For all systems described in this brochure, see important product usage information on the back cover.

In total loss lubrication systems, fresh lubricant (oil, grease or fluid grease) is constantly fed at certain intervals (depending on the time or load) to the friction points during the lubrication cycle (contact time, pump runtime).

The quantity of lubricant is dimensioned so that friction points are supplied with enough lubricant during the interval times to build up an adequate film of lubricant.

In the course of time, the lubricant is partially used up as a result of ageing, evaporation, bleeding and leaks (total loss lubrication). Heat cannot be dissipated with this lube method.

Additional expressions for total loss lubrication systems are customary in the literature and in catalogs, e.g.

- terminating lubrication
- once-through lubrication (in DIN ISO 5170)
- fresh-oil lubrication

The centralized lubrication units are manually, mechanically, electrically, hydraulically or pneumatically actuated piston pumps or intermittently operated gear pumps.

The lubricant is metered out by piston distributors installed in the tubing system. Exchangeable metering nipples on the distributors make it possible to supply every lube point with the requisite amount of lubricant per stroke or pump work cycle.

The metered quantities range from 0.01 to 1.5 cm³ per lubrication pulse and lube point. The amount of lubricant to be fed to the lube points can also be influenced by the number of lubrication pulses.

An oil return line from the lube point to the oil reservoir is not required on total loss lubrication systems.

The basic layout of a single-line total loss lubrication system is always the same:

- pump, piston distributor,
- main line (connection: pump – distributor),
- secondary line (connection: distributor – lube point).

Automatically operated systems also come with control and monitoring units, pressure switches, float switches, indicator lights.

Example of systems

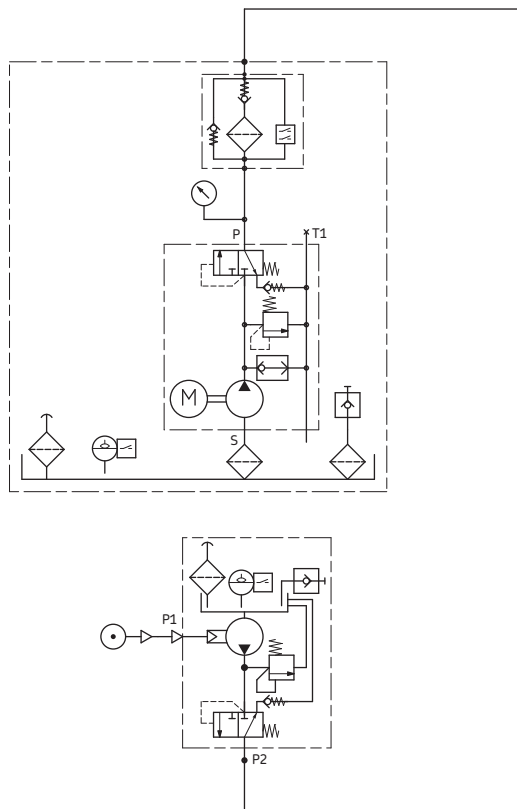

Diagram 1: Gear pump unit, model MFE

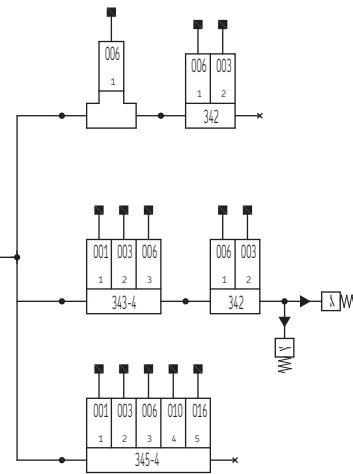

Diagram 2: Piston pump, pneum. actuated

Single-line total loss lubrication system

Gear pumps

Because of their electric drive, gear pumps are especially well-suited for automatic systems with monitoring and safety equipment. They can also be operated using pushbutton remove control systems.



Piston pumps

Piston pumps have a limited delivery volume per stroke. As a result, there are limits on the metered quantities and size of a system. Piston pumps are used in the following forms: manually, mechanically, electrically, hydraulically or pneumatically actuated pumps.



Piston distributors / metering units

Piston distributors (metering units, dosing valve) meter out and distribute the oil delivered by the pump (e.g. oil or grease of NLGI grades 000 or 00). The quantities of lubricant for the individual lube points are determined by exchangeable metering nipples. The metered quantity is shown on the individual nipples. Four groups of distributors that differ in terms of metering ranges and sizes can be selected so they comply with the amounts required and space available. A mixture of different distributor groups can be used in one system.



Circulating lubrication systems

After passing the friction point, the lubricant is fed back to the lubricant reservoir so that it can be used again.

Circulating lubrication systems are used everywhere they are necessary, not only to reduce wear but also to carry off heat at the friction point.

In the field of centralized lubrication technology, it is possible to classify circulating systems as follows:

- The lubricant delivered by a pump is split up by hydraulic resistors (orifice tubes, adjustable metering valve distributors, throttles)
- Volumetric apportioning of the output by flow limiters or progressive feeders
- Volumetric apportioning of the output by multicircuit pumps, e.g. multicircuit gear pumps or multicircuit piston pumps with one pump each per lube point.

Restrictor tubes

The oil is distributed and the flow split up by way of tubes with varying cross sections and lengths; the most symmetrical arrangement possible should be provided for.

Pressure losses in the main line are kept low all the way to the branch lines.

Application notes:

- a few cm³ up to several liters per lube point
- pressure: 2 to 20 bars
- simple systems insensitive to dirt
- dependable
- only monitoring of the main line possible
- complicated planning of large systems
- viscosity-dependent

Metering valve distributors

The quantity of oil is divided up by metering valve distributors and adjustable restrictor valves.

Application:

- 0 ... 2 000 cm³/min
- pressure: 2 to 10 bars
- only monitoring of the main line possible
- microfilters required
- easy to plan
- viscosity-dependent

Screw-in metering valves

The oil is distributed via nonadjustable restrictor cross sections.

Application:

- 0.2 to 230 cm³
- pressure: 2 to 20 bars
- only monitoring of the main line possible
- microfilters required
- easy to plan
- for installation at lube points or on manifolds
- viscosity-dependent

Flow monitor

Systems with throttles and flow monitors are used to monitor critical individual lube points where considerable disruptions and damage can be expected from even a brief lubrication failure.

Throttles are used to divide up the delivered quantity of lubricant. The downstream flow monitors should be installed as close as possible to or directly on the lube point

Application:

- 50 cm³/min to 14 l/min
- pressure: 4 (6) to 30 bars
- monitoring of the main line and/or lube point via microswitches
- viscosity-dependent

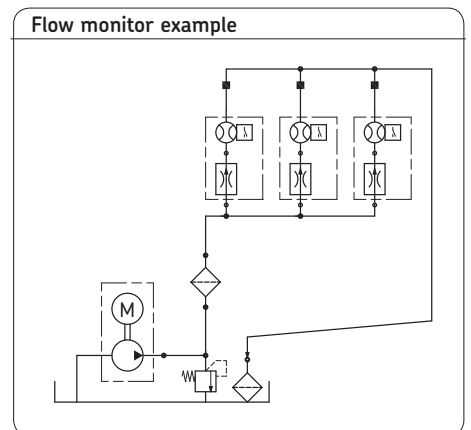
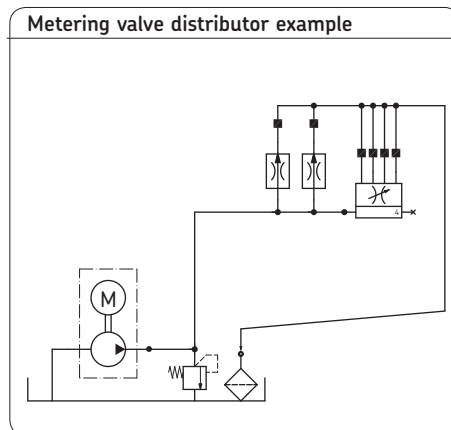
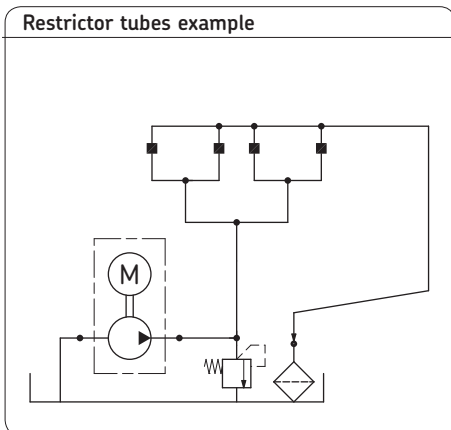

Circulating lubrication systems

Flow meter

A pump feeds into a tubing network. A constant pressure is maintained in the main line by way of a pressure control valve or frequency controlled pump. The quantity is allocated by way of adjustable restrictors. The amount set is measured and monitored by gear-type flow indicators.

Application:

- 0.05 to 40 l/min
- pressure: 5 to 40 bars
- mainly on paper machines
- dependable, maintenance-free and flexible
- bypass system
- service-friendly thanks to flushing port upstream of the restrictor

Progressive feeder

The pump's entire output is divided up into partial amounts by a master feeder and the secondary feeders connected to it.

Application:

- a few cm³ to 6 l/min
- pressure: 5 to 400 bars
- easy monitoring
- exact apportioning of output, even with back pressures
- largely viscosity-independent

Flow limiter

A pump feeds into the main line, from which the branch redirects the flow to the flow limiters.

A largely constant partial quantity is fed through each flow limiter to the downstream loads (lube points). This sum of partial quantities always has to be smaller than the pump's total delivery rate.

Application:

- 0.1 l/min to 100 l/min
- pressure: 6 to 50 bars
- volumetric flow is independent of the system pressure and also nearly viscosity-independent
- easy system planning
- effective monitoring of volumetric flow by means of a gear-type flow indicator with Hall sensor
- optionally available in an ATEX version
- nearly viscosity-independent

Multi-circuit pump

Multicircuit pumps with separate delivery circuits (gear pumps) feed constant amounts of lubricant to the lube points.

They ensure an even distribution of oil, even with varying back pressure.

The pumps are self-priming or are fed by a priming pump when high pressures are involved.

Application:

- 0.015 l/min to 1.2 l/min per outlet port
- pressure: 20 to 80 bars
- 2 to 20 delivery circuits
- easy to plan
- easy monitoring of functions
- for hydrostatic systems
- no distributors required

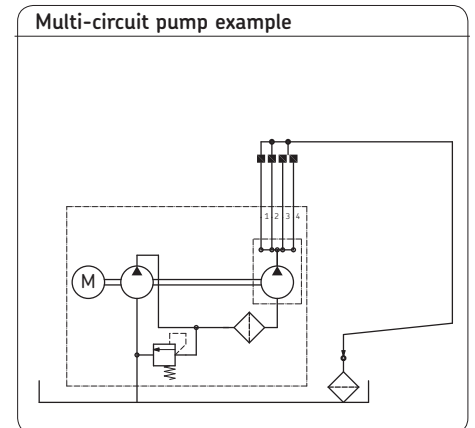
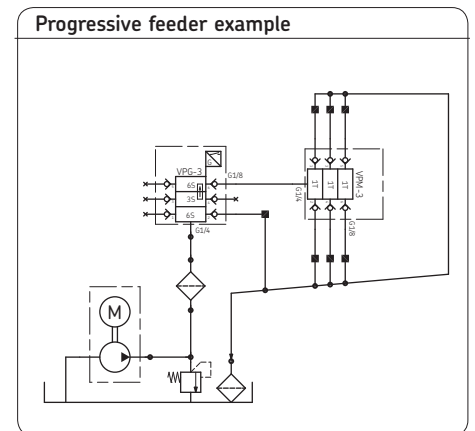
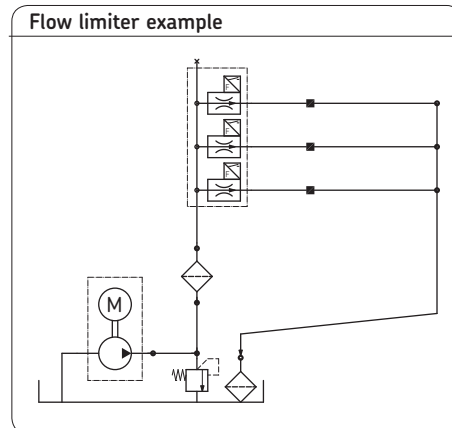
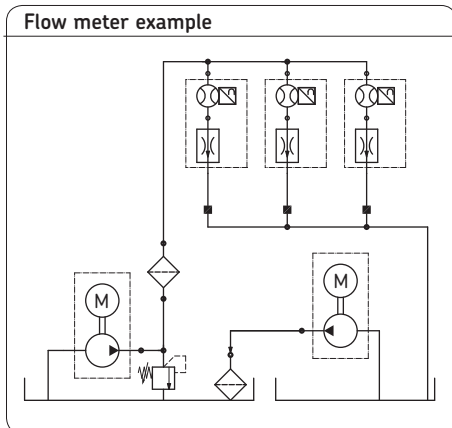

Hydrostatic lubrication

In the case of hydrostatic bearings, the oil pressure conforming to the carrying force is produced in pumps outside the bearings, the oil being fed under this pressure to the recesses, from which it flows out through the bearing gap.

Three systems with different characteristics are available:

- a) Restrictor system
- b) One pump delivery circuit per recess (multi-circuit pump system)
- c) Diaphragm restrictors

to b) One pump circuit per recess (multi-circuit pump system)

This system has a relatively good curve, and the costs are within reasonable limits, which is why this system is chosen most often.

The lower the delivery rate per circuit, the lower the oil viscosity and the greater the pump pressure, the more the delivery rates of the circuits differ from each other.

The difference in pressure in a multi-circuit pump can be limited by using a priming pump, which improves the evenness of the oil flow.

The total output of the multi-circuit pump and the requisite recess pressure per delivery circuit, with due consideration given to the permissible difference in pressure, determines the selection of this priming pump.

The recess pressure can be kept within the desired limits via the recess size, and a medium-viscosity oil should be your goal, with the exception of a few special tasks.

In the case of bearing assemblies that are subject to great fluctuations in pressure, it is possible for the priming pressure to be adjusted to the respective pressure of a characteristic recess with the help of a proportioning pressure valve.

Oil+Air lubrication

Oil+air lubrication is minimal quantity metering.

A drop of oil is pulled apart in streaks by a current of air in a narrow tube. It is then transported in the direction of the lube point.

The bearing is continuously supplied with fine droplets of oil from the outlet nozzle. The carrier air leaves the bearing nearly free of oil.

The main applications are found in the field of mechanical engineering, where high demands such as assurance of high efficiency with low wear and long service life, especially in the case of tool spindles, are made on defined lubrication.

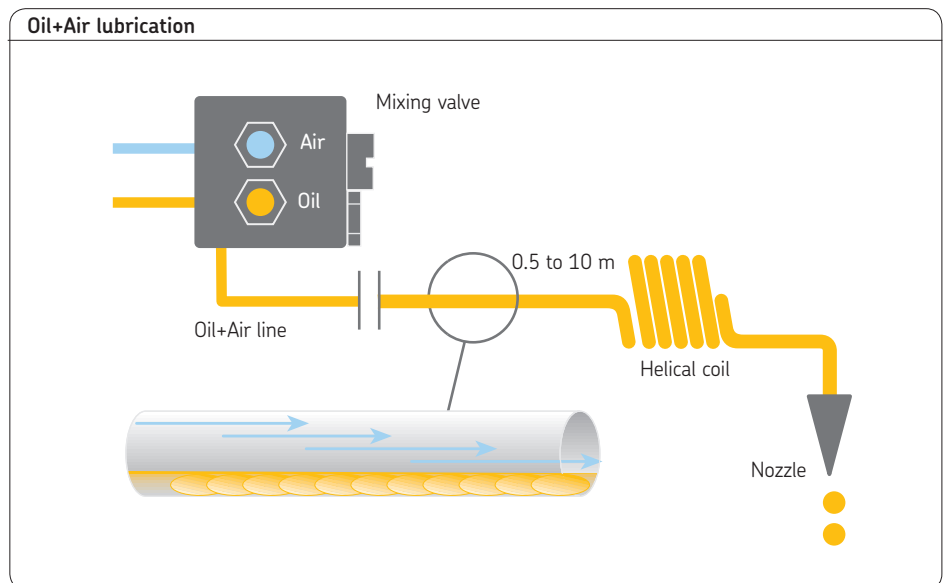

Minimal quantity metering systems

for the metering of small quantities of lubricant

Application

Minimal quantity metering systems are typically used for the

- lubrication of tools,
- oiling of joined parts,
- spraying or wetting of surfaces,
- lubrication of chains,
- relubrication of linear guides and rolling bearings.

These systems are an ideal, low-cost alternative when no centralized lubrication system is available. They are distinguished by low maintenance and operating costs.

Compact greaser

Electrically operated micropump with 2 or 5 outlet ports and an exchangeable grease cartridge with an 80 cm³ capacity, for grease belonging to NLGI classes 000 to 2.



Magnetic piston pump

Positive displacement pump with 2, 4 or 6 outlet ports actuated by solenoid actuator.



Injection oiler

Pneumatically actuated positive displacement pump with adjustable volume from 0 to 30 mm³, for oil and grease up to NLGI grade 2.



Regreasing cartridge ETPC1

Electrothermal pump compact (ETPC) for spindle bearings.

Compact design for easy integration in the spindle.

- Grease cartridge 2.5 cm³
- Metering volume 6 mm³ / stroke
- Suitable for grease, NLGI grade 2



Pressure curves in the main lines of central lubrication systems complies with DIN24271

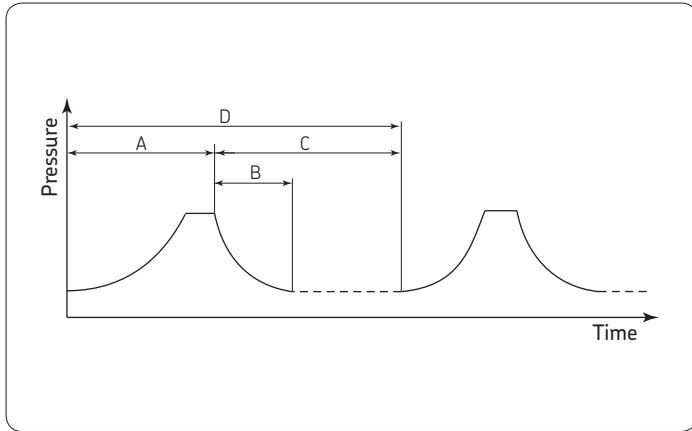

Single-line system with single-line prelubrication distributor

Due to the lubricant pressure resulting from the pressure build-up in the main line, a metered quantity of lubricant is briefly fed (directly) from the single-line prelubrication distributor to the lube point after overcoming the resistance that can occur all the way to the friction point. When the pressure of the system's safety valve is reached, the pressure does not continue to rise while the pump is still running. The pressure-relief time (B) begins when the pump stops. During the pressure-relief time (B) the pressure in the main line is reduced to a residual pressure with the help of a pressure-relief valve, while a metered amount of lubricant for the next lubrication cycle is being readied in the single-line distributor by spring force. The interval at which one lubrication cycle follows the next is determined by the interval time (C), which can be preselected with, for example, the help of a timer.

A = Lubrication cycle time
 B = Pressure-relief time
 C = Interval time $B \leq C$
 D = Work cycle time $A + C = D$

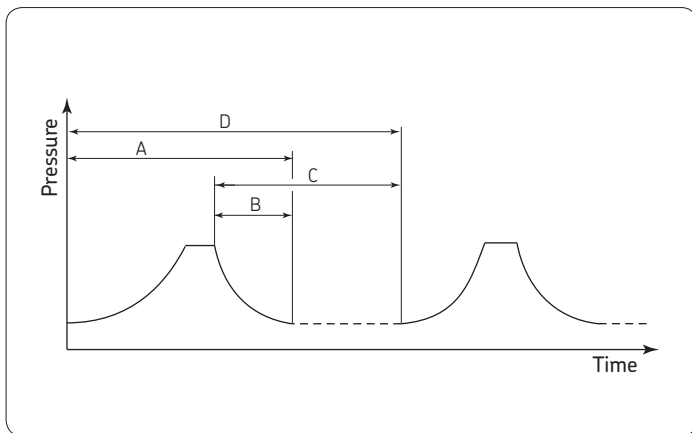

Single-line system with single-line relubrication distributor

When the pump is running, a metered amount of lubricant is readied in the single-line relubrication distributor, this quantity subsequently being passed on indirectly to the lube point by the force of a pressure spring in the distributor when the pressure-relief time (B) commences. The discharge of lubricant to the lube point takes a while, depending on the resistance encountered up to the friction point.

A = Lubrication cycle time
 B = Pressure-relief time
 C = Interval time $B \leq C$
 D = Work cycle time $A \leq D$

Viscosity/temperature relationship of oils with different basic viscosities

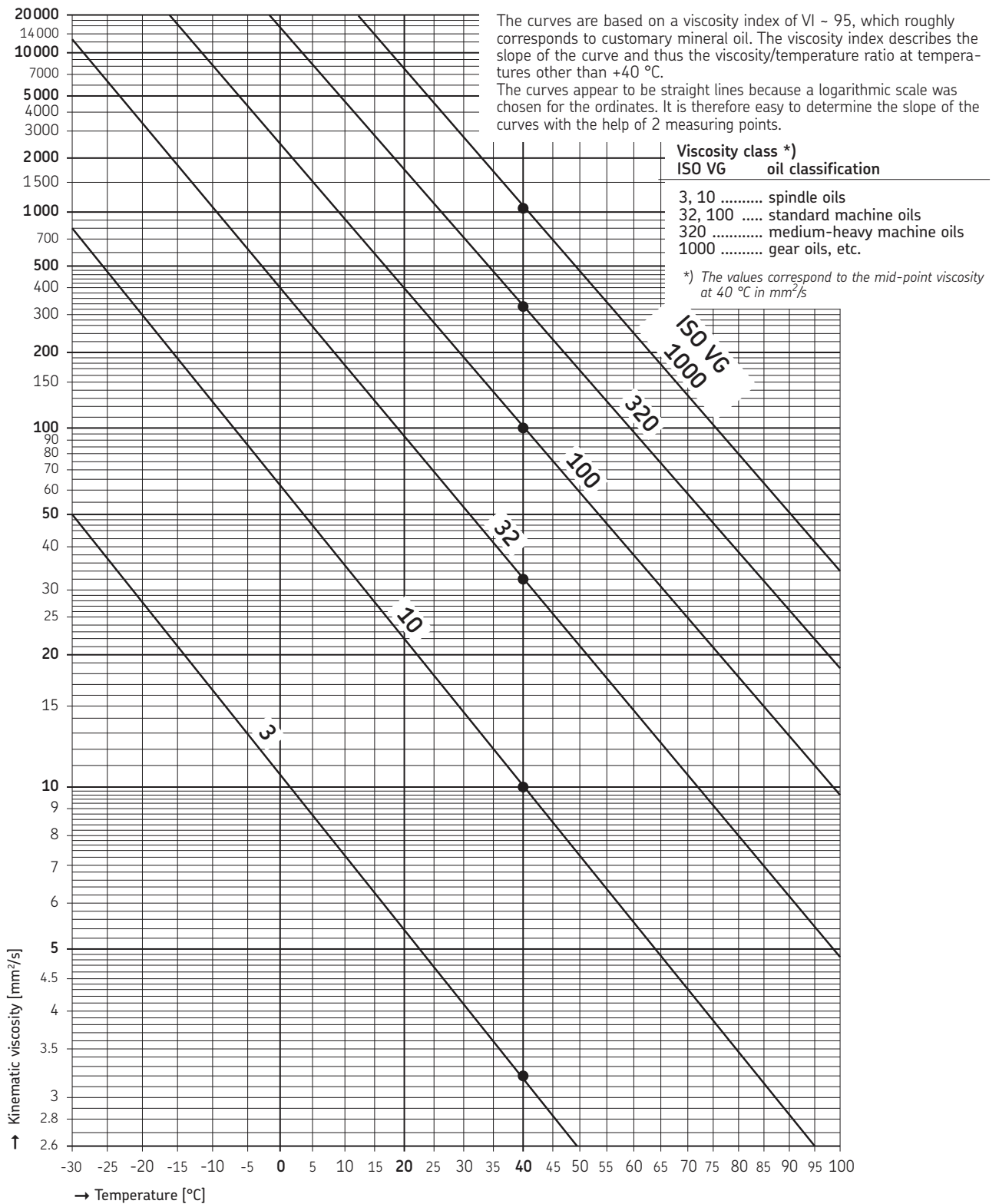

Please note: the change in the viscosity of oil is incomparably greater at lower temperatures than in higher temperature ranges. For example, there are the following changes in viscosity for an oil with a rated viscosity of 100 in different temperature ranges at the same temperature difference:

| | |
|-----------------------------------|-------------------------------------|
| at +80 °C = 18 mm ² /s | at +10 °C = 875 mm ² /s |
| vs. | |
| at +75 °C = 21 mm ² /s | at + 5 °C = 1450 mm ² /s |
| change of 3 mm ² /s | change of 575 mm ² /s |

Graphic symbols for the representation of central lubrication systems in technical drawings

(Excerpt of examples from our online production program. Further symbols can be found on the Internet at: www.skf.com/lubrication)

General

Lube point
This is where lubricant is fed to the friction point.



Pumps

Piston pump, pneumatically actuated, with oil reservoir
Example: POEP-15-1.0W
See brochure 1-1111-EN

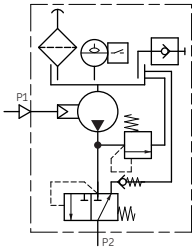

Piston pump, pneumatically actuated, with grease reservoir
Example: PFP-23-2
See brochure 1-0107-4-EN

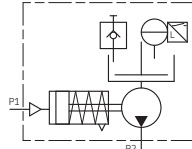

Multi-circuit gear pump unit with oil reservoir
Example: ZM505-BW51
See brochure 1-1204-EN

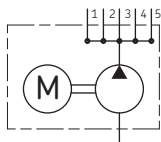

Gear pump unit with oil reservoir
Example: MFE5
See brochure 1-1202-EN

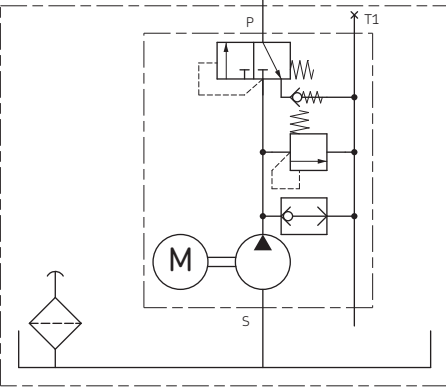

Please note!
The symbols shown were taken from DIN ISO 1219 and DIN 24271 or were composed using the basic symbols shown there.

Distributors

Piston distributor (single-line distributor)
Example: 353-... (3-way)
See brochure 1-5001-EN

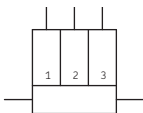

Metering valve distributor, adjustable
Example: 242-034.00 (3-way)
See brochure 1-5006-EN

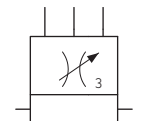

Progressive feeder
Example: VPM-4 (8-way)
See brochure 1-3016-EN

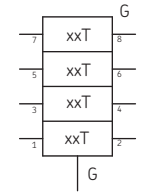

Valves, switches

Safety valve, adjustable
Example: WVN200-10E25
See brochure 1-0103-EN



Pressure relief valve
Example: 202-275-2
See brochure 1-0103-EN

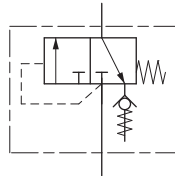

Pressure switch
Example: DS-W20
See brochure 1-1701-EN

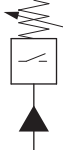

Float switch
Example: WS33-2
See brochure 1-1702-EN

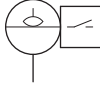

Order No. 1-0002-EN

Subject to change without notice! (07/2014)

Important product usage information

All products from SKF may be used only for their intended purpose as described in this brochure and in any instructions. If operating instructions are supplied with the products, they must be read and followed.

Not all lubricants are suitable for use in centralized lubrication systems. SKF does offer an inspection service to test customer supplied lubricant to determine if it can be used in a centralized system. SKF lubrication systems or their components are not approved for use with gases, liquefied gases, pressurized gases in solution and fluids with a vapor pressure exceeding normal atmospheric pressure (1013 mbars) by more than 0.5 bar at their maximum permissible temperature.

Hazardous materials of any kind, especially the materials classified as hazardous by European Community Directive EC 67/548/EEC, Article 2, Par. 2, may only be used to fill SKF centralized lubrication systems and components and delivered and/or distributed with the same after consulting with and receiving written approval from SKF.

Additional brochures

1-9201-EN Transport of Lubricants in Centralized Lubrication Systems

SKF Lubrication Systems Germany GmbH

Motzener Strasse 35/37 · 12277 Berlin · Germany
PF 970444 · 12704 Berlin · Germany
Tel. +49 (0)30 72002-0 · Fax +49 (0)30 72002-111
www.skf.com/lubrication

This brochure was presented by:

® SKF is a registered trademark of the SKF Group.

© SKF Group 2014

The contents of this publication are the copyright of the publisher and may not be reproduced (even extracts) unless prior written permission is granted. Every care has been taken to ensure the accuracy of the information contained in this publication but no liability can be accepted for any loss or damage whether direct, indirect or consequential arising out of the use of the information contained herein.

